

**96980014****I** **NORME PER LA RICHIESTA DEI PEZZI DI RICAMBIO**

Nella richiesta dei pezzi di ricambio devono essere forniti i seguenti dati:

- 1) Numero di tavola, numero di posizione, codice di ordinazione e quantità come sono indicati nel presente libretto.
- 2) Il tipo della macchina ed il numero di matricola della macchina che è riportato sulla copertina del libretto e sulla targhetta situata nel telaio.
- 3) L'indicazione completa del nominativo ed indirizzo del committente.

IMPORTANTE

Si fa presente che, in mancanza dei dati sopra indicati, la Ditta non sarà in grado di dare corso alle evasioni dei ricambi.

AVVERTENZE

La Ditta costruttrice declina ogni responsabilità per danni a cose e persone derivati dallo scorretto uso della macchina di sua costruzione.

La Ditta costruttrice si riserva il diritto di apportare, in qualunque momento, e senza impegnarsi ad aggiornare tempestivamente questa pubblicazione, le eventuali modifiche di organi, dettagli o forniture che essa ritiene conveniente per migliorie funzionali e tecnologiche o per qualsiasi esigenza di carattere costruttivo o commerciale.

**F INSTRUCTIONS POUR LA DEMANDE DES PIÈCES DE RECHANGE**

Dans la demande des pièces de rechange les éléments suivants doivent être fournis:

- 1) Le numéro de la table, le numéro de la position, le code des pièces et la quantité suivant les indications données dans le présent livret.**
- 2) Le type de la machine et son numéro de matricule comme indiqué sur la couverture du livret et sur la plaque située dans le châssis.**
- 3) L'indication complète du nominatif et de l'adresse de l'acheteur.**

IMPORTANT

Veillez noter que, faute de données indiquées ci-dessus, la Société ne sera pas en mesure de donner cours aux évocations des rechanges.

AVERTISSEMENTS

La Société constructrice décline toute responsabilité pour d'éventuels dommages à choses et personnes causés par l'incorrecte utilisation de la machine de sa construction.

La Société constructrice se réserve le droit d'apporter, à tout moment et sans s'engager à mettre à jours à temps cette publication, les éventuelles modifications d'organes, détails ou fournitures d'accessoires qu'elle estime être avantageuses pour des améliorations fonctionnelles et technologiques ou pour toute exigence de caractère constructif ou commercial.

**GB SPARE PARTS REQUEST INSTRUCTIONS**

On the spare parts request the following data have to be mentioned:

- 1) The table and position number, the code reference of the part and the relevant quantity as they are mentioned in this booklet.**
- 2) The model of the machine and its serial number, as quoted on the booklet cover and on the plate placed on the frame.**
- 3) The fully information of the buyer's name and adress.**

IMPORTANT

We kindly ask you to take note that, lacking the above mentioned data, our Company will not be able to carry out the spare parts orders.

NOTICE

The Manufacturer declines any liability for damages to things and persons rising from an incorrect use of the machines of his manufacture.

The Manufacturer reserves the right to modify, at any moment and without engaging himself to immediately up-to-date this publication, parts, details or supplies, which he considers to be technological and functional improvements or for manufacturing or commercial needs.

**D** NORMEN FÜR DIE ERSATZTEILEANFRAGE

Bei Ersatzteilanfragen sind zu übermitteln:

- 1) Tafelnummer und Position des Ersatzteibuches und gewünschte Stückzahl.
- 2) Maschinentyp und Seriennummer (siehe Fahrzeugbrief und Herstellerschild).
- 3) Name und Adresse des Auftraggebers.

WICHTIG

Ohne die oben geforderten Daten ist es dem Unternehmen nicht möglich Ersatzteile korrekt auszuliefern.

ACHTUNG

Der Hersteller übernimmt keine Haftung für Personen- und Sachschäden welche durch unsachgemäßes bedienen der Maschinen entstehen.

Der Hersteller hält sich das Recht vor jederzeit, ohne Ankündigung, Änderungen im Rahmen von Weiterentwicklungen, und Verbesserungen an technischer Ausführung und im Design durchzuführen.

96990700

- I INDICE GRUPPI
- F INDEX DES GROUPS
- GB GROUPS INDEX
- D GRUPPENVERZEICHNIS

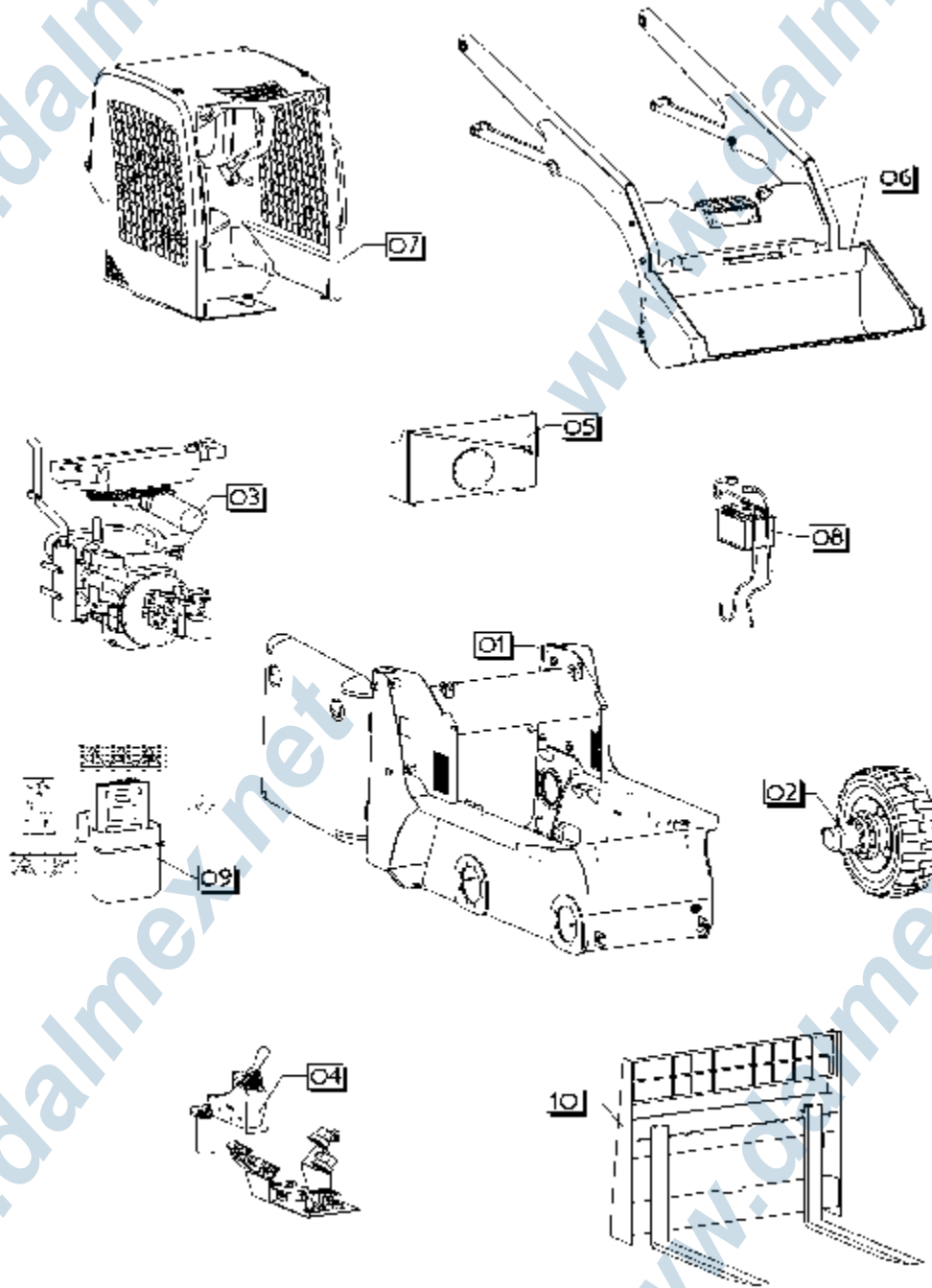



I INDICE GRUPPI
F INDEX DES GROUPS
GB GROUPS INDEX
D GRUPPENVERZEICHNIS

Tavole **01** **TELAIO**
 Tableaux **CHASSIS**
 Tables **FRAME**
 Tavein **RAHMEN**

Tavole **09** **DOTAZIONI - TARGHETTE**
 Tableaux **ACCESSOIRES - PLAQUETTES**
 Tables **EQUIPMENTS - LABELS**
 Tavein **AUSRÜSTUNG - SCHILDEN**

Tavole **02** **GRUPPI RUOTE**
 Tableaux **GROUPE ROUES**
 Tables **WHEELS GROUP**
 Tavein **RAEDERGRUPPE**

Tavole **10** **OPTIONALS**
 Tableaux **OPTIONALS**
 Tables **OPTIONALS**
 Tavein **SONDERZUBEHOR**

Tavole **03** **MOTORIZZAZIONE**
 Tableaux **MOTEUR**
 Tables **ENGINE**
 Tavein **MOTOR**

Tavole **04** **IMPIANTO OLEODINAMICO**
 Tableaux **INSTALLATION OLEODYNAMIQUE**
 Tables **OLEODYNAMIC SYSTEM**
 Tavein **OLEODYNAMISCHE ANLAGE**

Tavole **05** **SERBATOIO OLIO**
 Tableaux **RESERVOIR HUILE**
 Tables **OIL TANK**
 Tavein **OLTANK**

Tavole **06** **BRACCI - BENNA**
 Tableaux **BRAS - BENNE**
 Tables **SKIP - ARMS**
 Tavein **ARMEN - SCHAUFEL**

Tavole **07** **CABINA**
 Tableaux **CABINE**
 Tables **CAB**
 Tavein **KABINE**

Tavole **08** **IMPIANTO ELETTRICO**
 Tableaux **INSTALLATION ELECTRIQUE**
 Tables **ELECTRIC SYSTEM**
 Tavein **ELEKTRISCHE ANLAGE**



Tavola **01** **TELAIO**
Tableaux **CHASSIS**
Tables **FRAME**
Tavolin **RAHMEN**

01-01



01-02

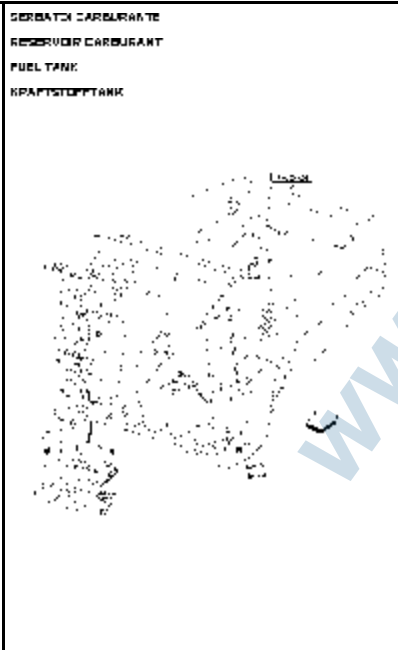

01-03

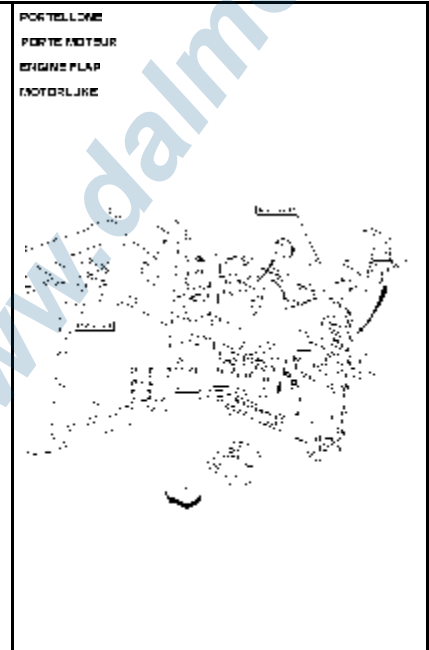

01-



01-

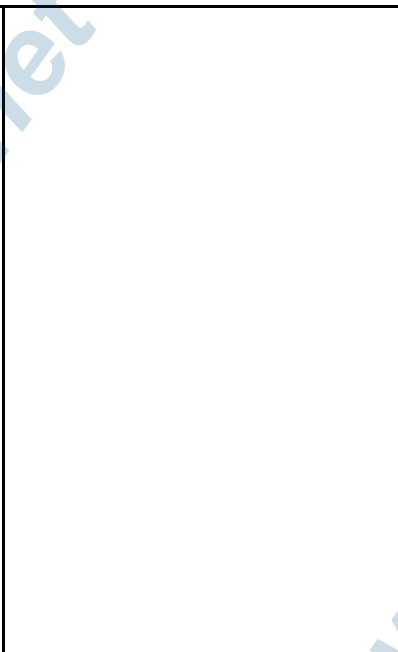

01-





Tavola **01** TELAIO
Tableaux **CHASSIS**
Tables **FRAME**
Tavain **RAHMEN**

01-

01-

01-

--	--	--

01-

01-

01-

--	--	--



Tavola **02** GRUPPI RUOTE
Tableaux GROUPE ROUES
Tables WHEELS GROUP
Tavain RAEDERGRUPPE

02-01

02-

02-

<p>GRUPPI RUOTE GROUPE ROUES WHEELS GROUP RAEDERGRUPPE</p> 		
---	--	--

02-

02-

02-

--	--	--



Tavola **02** GRUPPI RUOTE
Tableaux GROUPE ROUES
Tables WHEELS GROUP
Tavola RAEDERGRUPPE

02-

02-

02-

--	--	--

02-

02-

02-

--	--	--



Tavola **03** **MOTORIZZAZIONE**
 Tableaux **MOTEUR**
 Tables **ENGINE**
 Tavein **MOTOR**

03-01



03-02

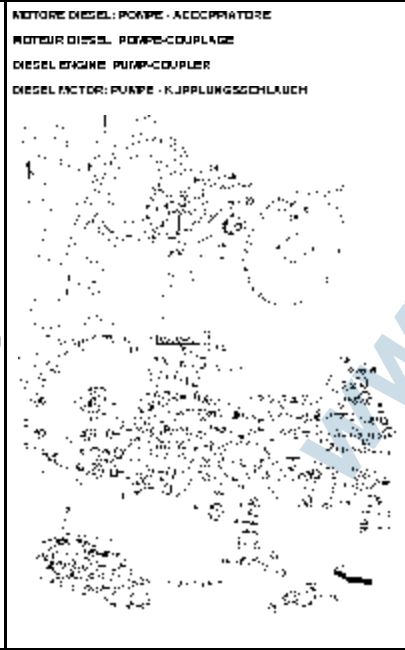

03-03

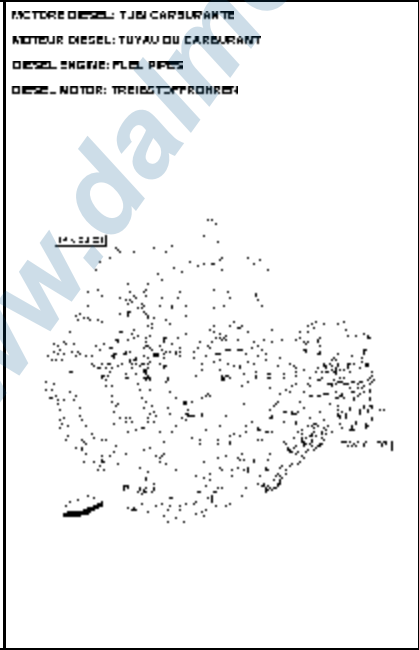

03-04



03-05

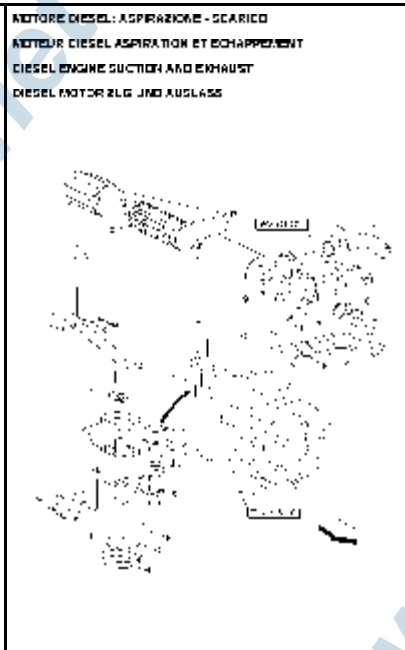

03-06





Tavola **03** **MOTORIZZAZIONE**
 Tableaux **MOTEUR**
 Tables **ENGINE**
 Tabein **MOTOR**

03-07

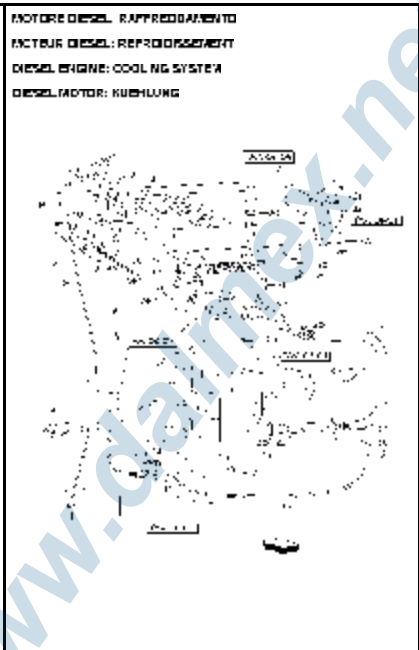

03-08



03-



03-



03-

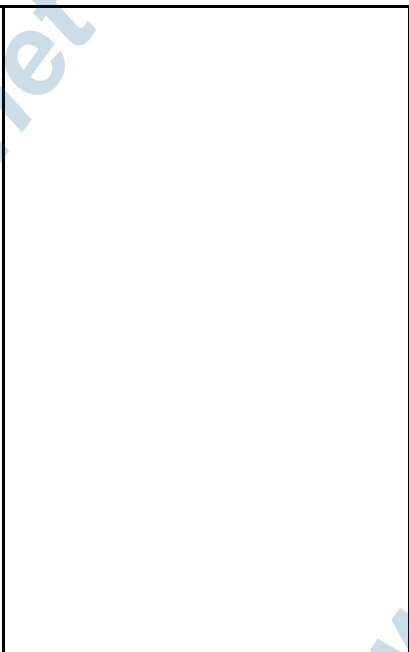

03-





Tavola **04** IMPIANTO OLEODINAMICO
 Tableaux **04** INSTALLATION OLEODINAMIQUE
 Tables **04** OLEODYNAMIC SYSTEM
 Tabein **04** OELDYNAMISCHE ANLAGE

04-01

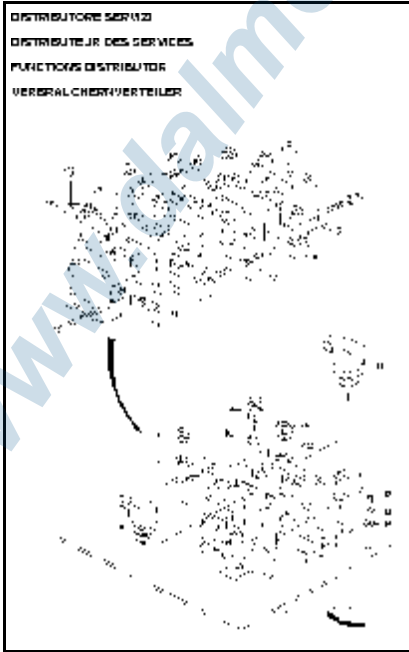

04-02



04-03

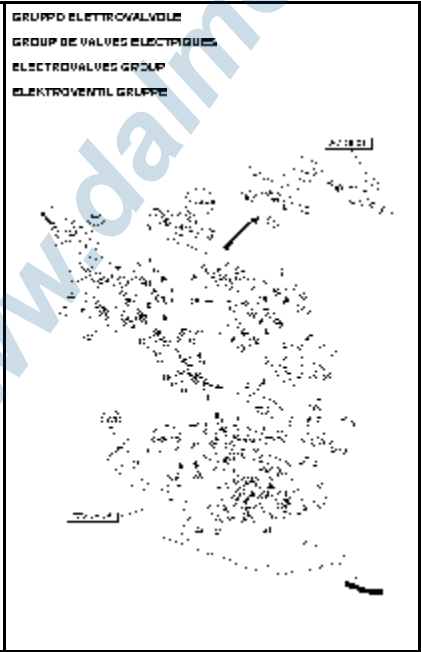

04-04



04-05

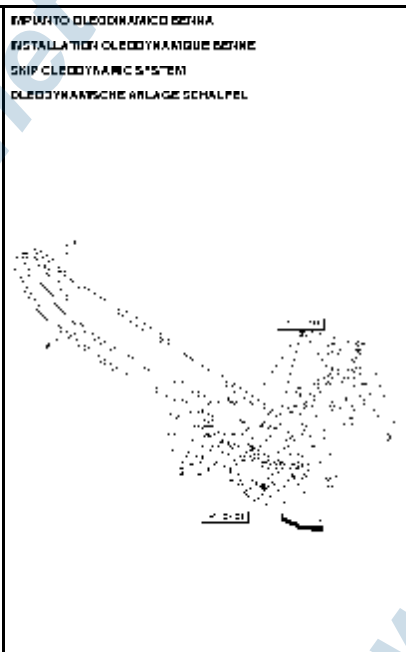

04-06





Tavola **04** IMPIANTO OLEODINAMICO
 Tableaux **04** INSTALLATION OLEODYNAMIQUE
 Tables **04** OLEODYNAMIC SYSTEM
 Tabein **04** OELDYNAMISCHE ANLAGE

04-07

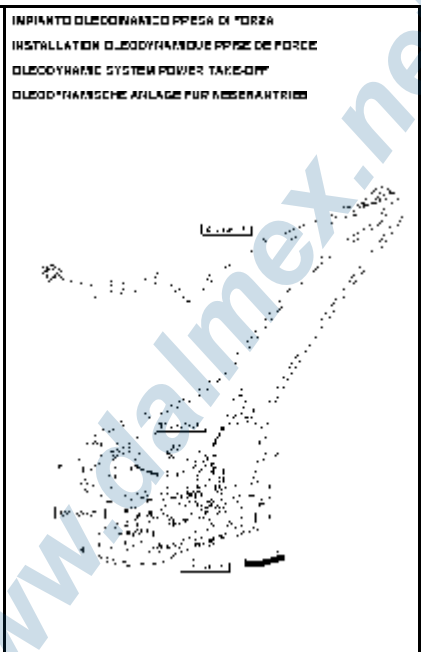
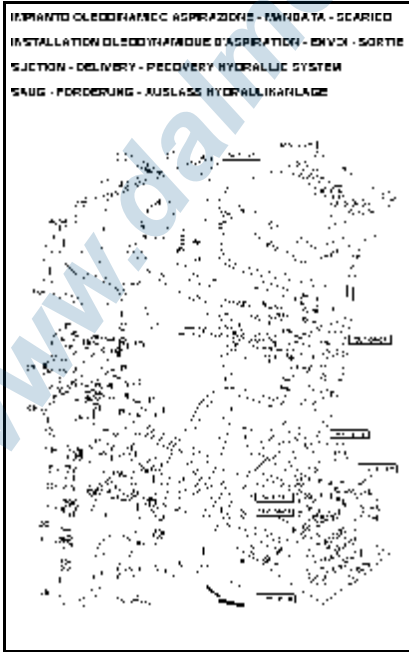

04-08

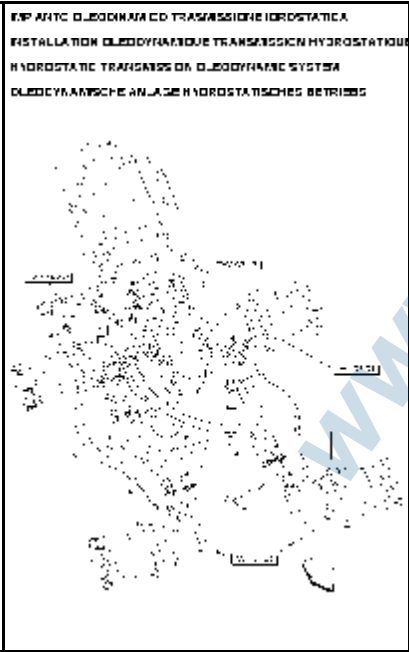

04-09



04-10



04-

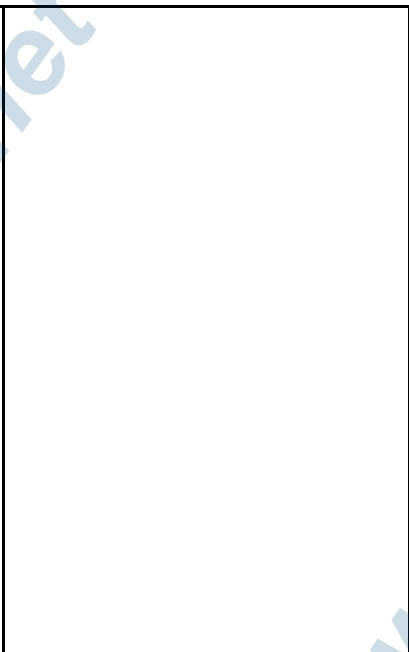

04-





Tavola **05** SERBATOIO OLIO
Tableaux RESERVOIR HUILE
Tables OIL TANK
Tavola OILTANK

05-01

05-

05-

<p>SERBATOIO OLIO RESERVOIR HUILE OIL TANK OILTANK</p> 		
---	--	--

05-

05-

05-

--	--	--



Tavola **05** SERBATOIO OLIO
Tableaux **05** RESERVOIR HUILE
Tables **05** OIL TANK
Tavola **05** OILTANK

05-

05-

05-

--	--	--

05-10

05-

05-

--	--	--



Tavola **06** BRACCI - BENNA
Tableaux **BRAS - BENNE**
Tables **SKIP - ARMS**
Tavain **ARMEN - SCHAUFEL**

06-01

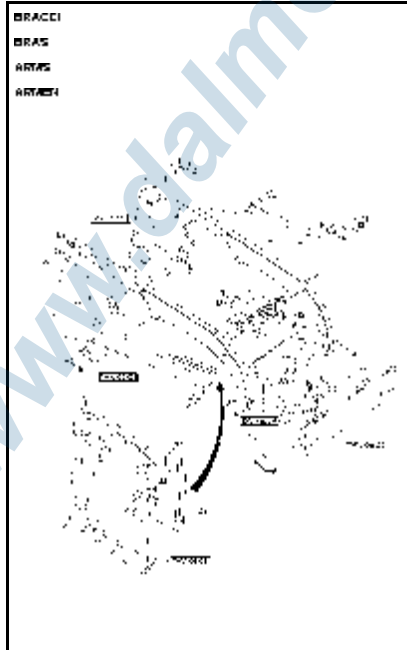

06-02



06-03



06-



06-

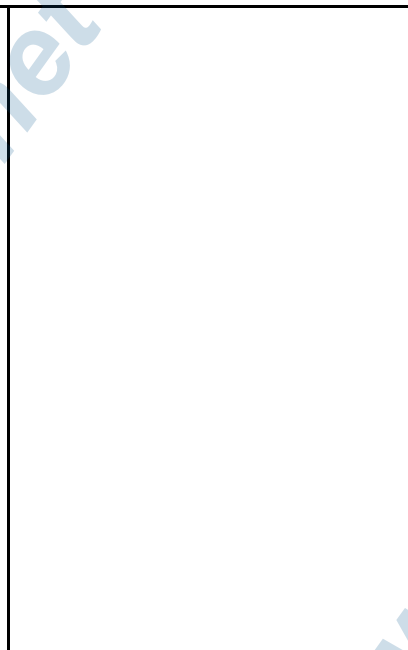

06-





Tavola **06** BRACCI - BENNA
Tableaux **BRAS - BENNE**
Tables **SKIP - ARMS**
Tavola **ARMEN - SCHAUFEL**

06-

06-

06-

--	--	--

06-

06-

06-

--	--	--



Tavola	07	CABINA
Tableaux		CABINE
Tables		CAB
Tavain		KABINE

07-01



07-02



07-03

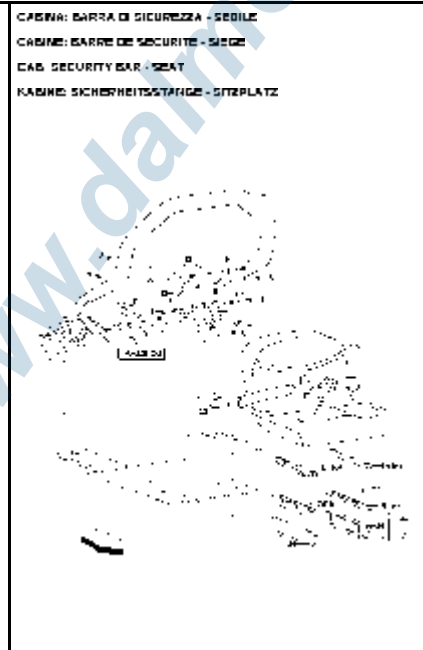

07-



07-

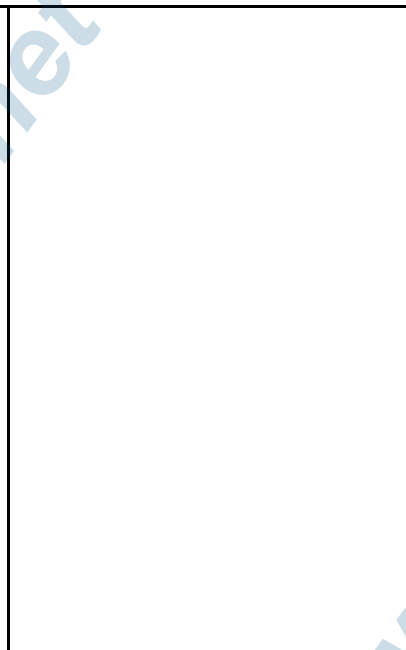

07-





Tavola **07** CABINA
Tableaux CABINE
Tables CAB
Tavola KABINE

07-

07-

07-

--	--	--

07-

07-

07-

--	--	--



Tavola **08** IMPIANTO ELETTRICO
 Tableaux **08** INSTALLATION ELECTRIQUE
 Tables **08** ELECTRIC SYSTEM
 Tavein **08** ELEKTRISCHE ANLAGE

08-01



08-02

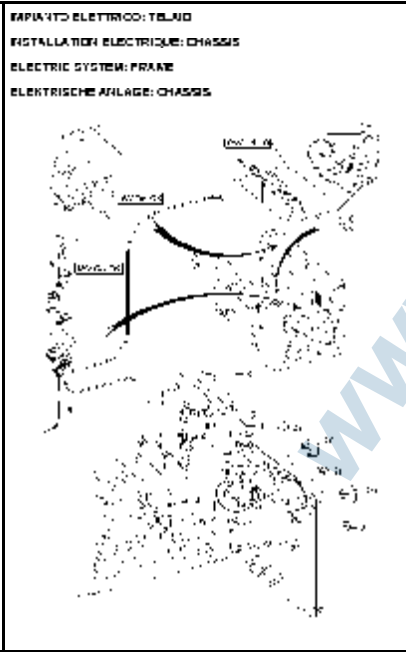

08-03

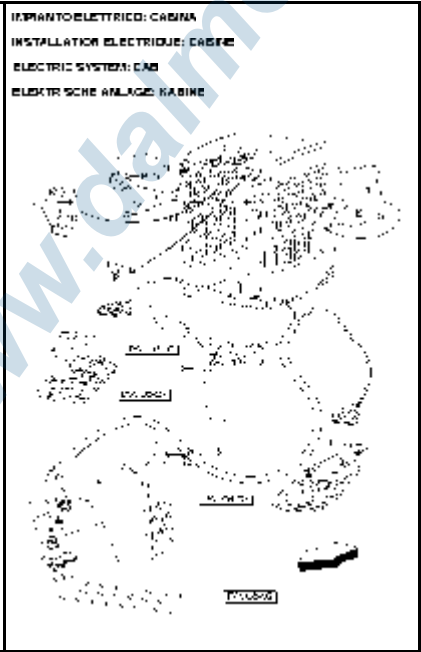

08-04

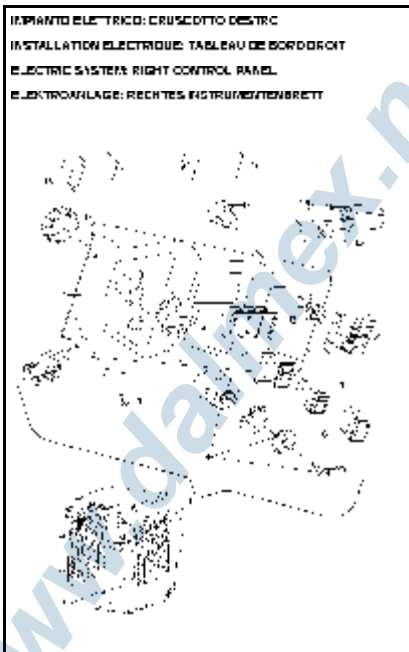

08-05

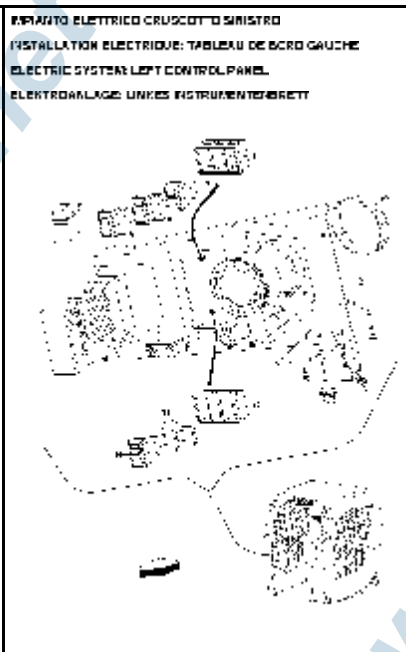

08-





Tavola **08** IMPIANTO ELETTRICO
Tableaux **08** INSTALLATION ELECTRIQUE
Tables **08** ELECTRIC SYSTEM
Tavola **08** ELEKTRISCHE ANLAGE

08-

08-

08-

--	--	--

08-

08-

08-

--	--	--



Tavols **09** DOTAZIONI - TARGHETTE
 Tableaux **09** ACCESSOIRES - PLAQUETTES
 Tables **09** EQUIPMENTS - LABELS
 Tavein **09** AUSRÜSTUNG - SCHILDEN

09-01

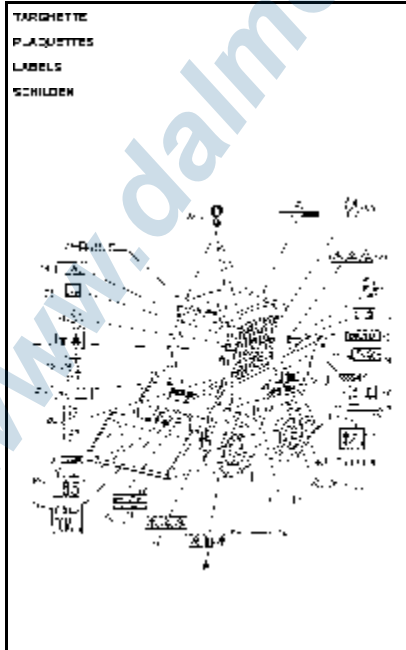

09-02



09-



09-



09-

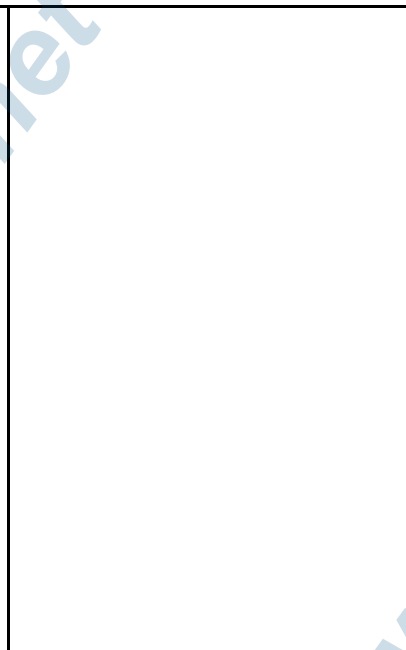

09-





Tavols **09** DOTAZIONI - TARGHETTE
Tableaux ACCESSOIRES - PLAQUETTES
Tables EQUIPMENTS - LABELS
Tavain AUSRUSTUNG . SCHILDEN

09-

09-

09-

--	--	--

09-

09-

09-

--	--	--



Tavola **10** **OPTIONALS**
 Tableaux **OPTIONALS**
 Tables **OPTIONALS**
 Tavein **SONDERZUBEHOR**

10-01

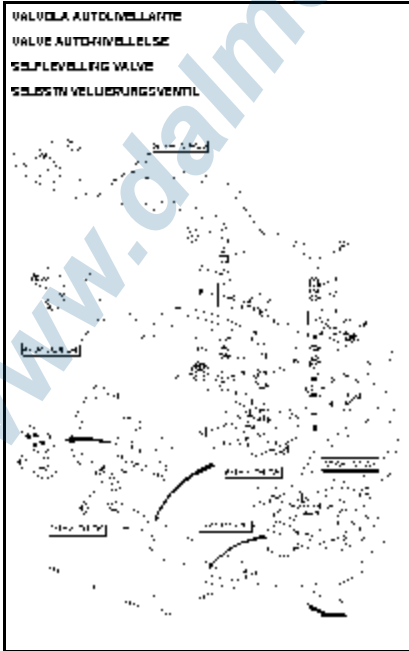

10-02

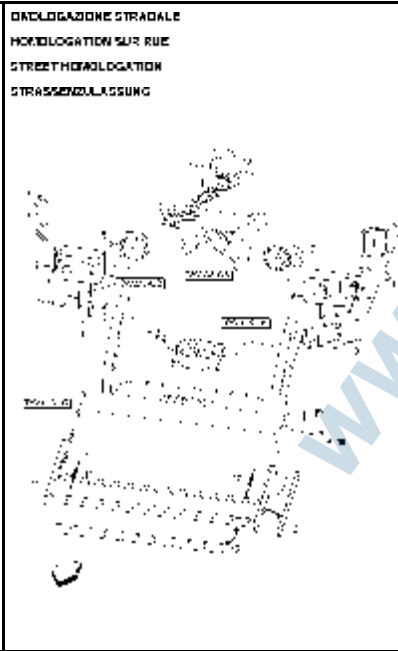

10-03

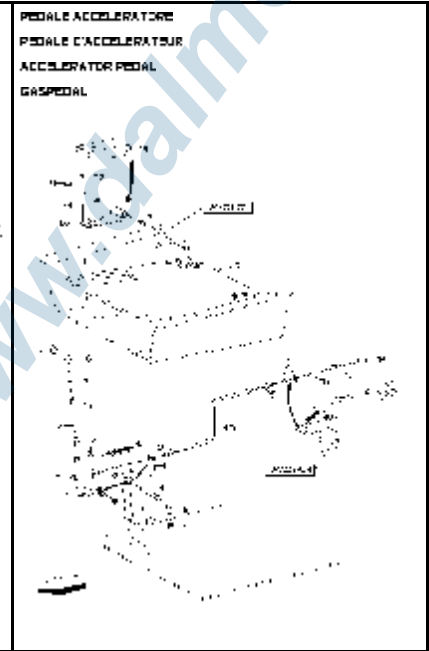

10-04

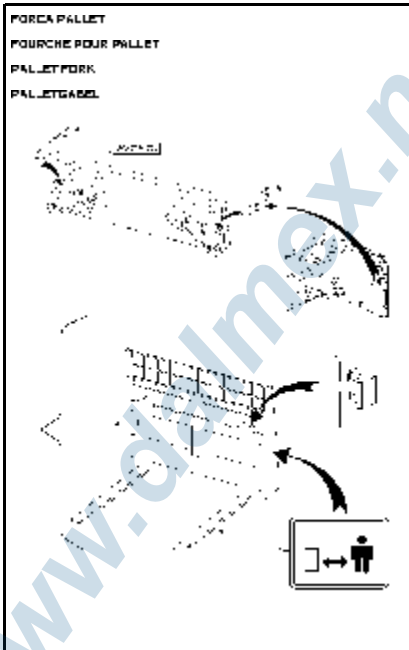

10-05

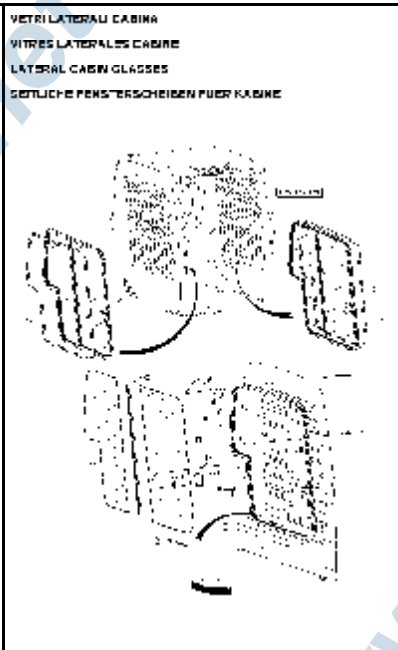

10-06





Tavola **10** **OPTIONALS**
 Tableaux **OPTIONALS**
 Tables **OPTIONALS**
 Tavein **SONDERZUBEHOR**

10-06A



10-06B

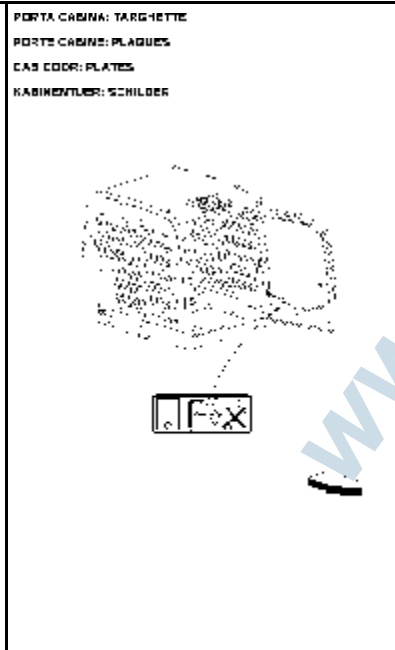

10-07



10-08

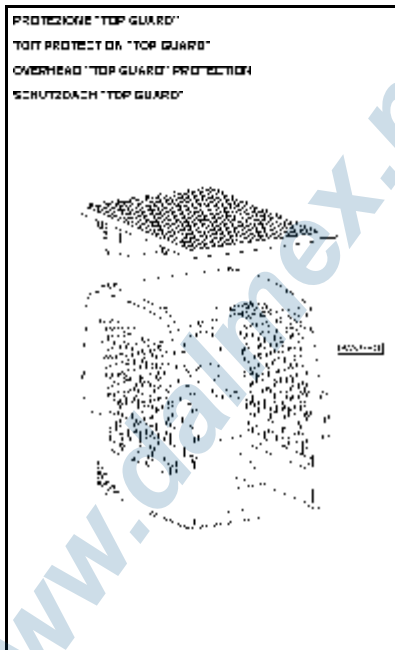

10-

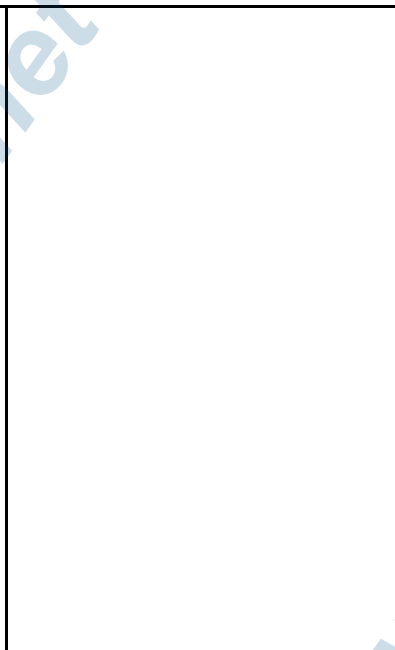

10-





9699201

I PARTI DI RICAMBIO

F PIÈCES DE RECHANGE

GB SPARE PARTS

D ERSATZTEILE

www.dalmex.net

www.dalmex.net



www.dalmex.net

www.dalmex.net

www.dalmex.net

www.dalmex.net





- Ⓛ TELAIO
- Ⓧ CHASSIS
- Ⓞ FRAME
- Ⓛ RAHMEN

TAV. 01-01
96010149

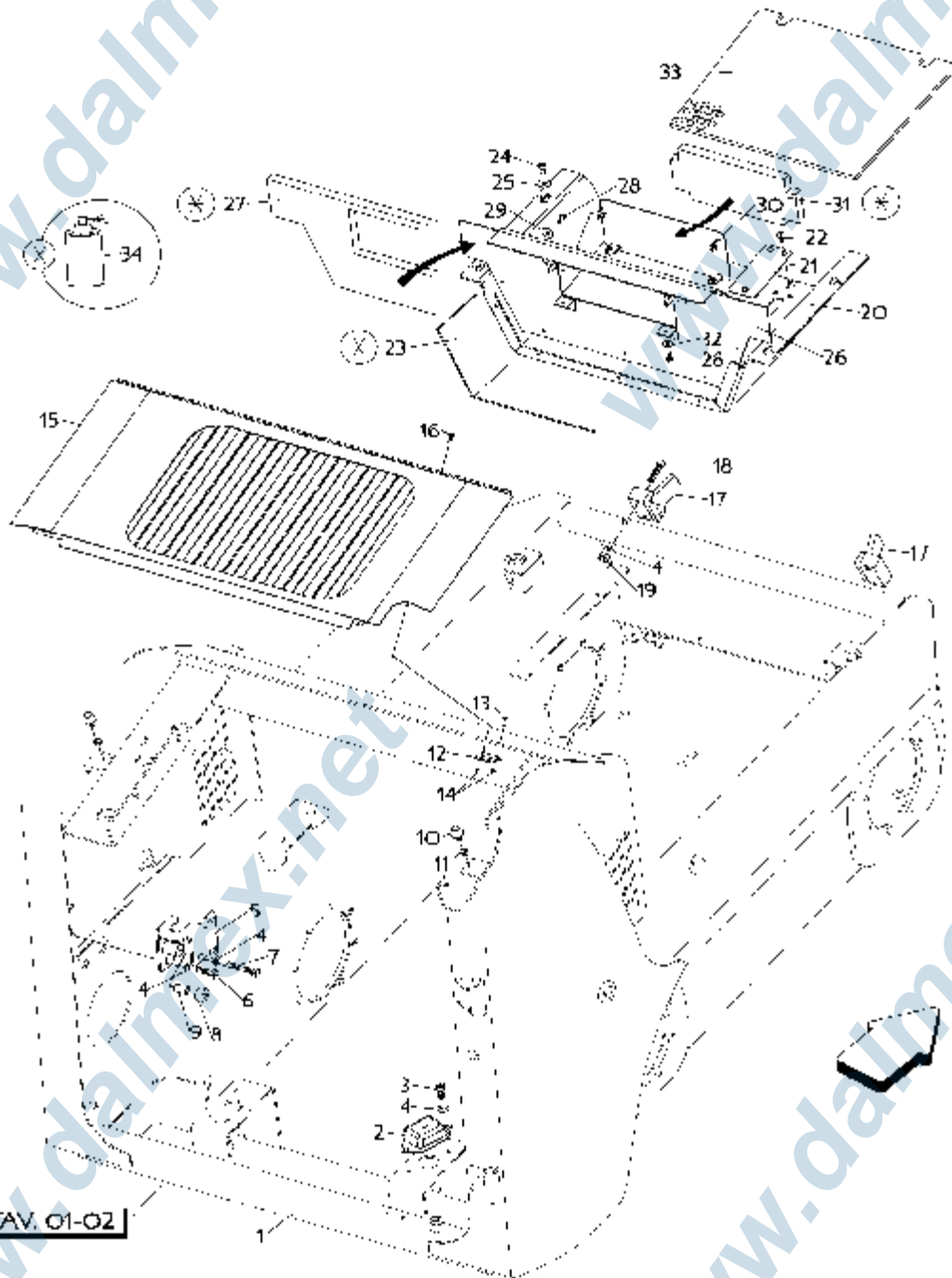

TAV. 01-02



Tav. 01-01 - 96010149

P.	Codice	Q.	① ②	Denominazione Benennung	③	Description	④	Description
1	55012080	1		CLASSI		CLASSI		CLASSI
2	03520201	4		ANTIVIBAZIONE DAMP LINE		ANTIVIBAZIONE		VIBRAZIONE DAMPING
3	03244790	8		VITI SOLLAZIONI		VITI		SCHRAUBEN
4	03386050	15		ROSELE SCELLE		ROSDREH		WASSEL
5	95100049	1		RISORCENTRICO ANNOILAG		LEISTUNG		TRABEIT
6	03240501	2		VITI SOLLAZIONI		VITI		SCHRAUBEN
7	03241100	1		VITI SOLLAZIONI		VITI		SCHRAUBEN
8	95100053	1		CHIAVILLI CHIAVILLI		VITEN		HEBELN
9	95100052	1		CHIAVILLI CHIAVILLI		VITEN		HEBELN
10	03529600	2		ANTIVIBAZIONE DAMP LINE		ANTIVIBAZIONE		VIBRAZIONE DAMPING
11	03364001	2		ROSELE MULTI		ROSDREH		WASSEL
12	03780004	3		CHIAVILLI SOLLAZIONI		HEBELN		HEBELN
13	03207700	6		VITI SOLLAZIONI		VITI		SCHRAUBEN
14	03362100	12		ROSELE MULTI		ROSDREH		WASSEL
15	30013229	1		CHIAVILLI SOLLAZIONI		HEBELN		HEBELN
16	03207695	6		VITI SOLLAZIONI		VITI		SCHRAUBEN
17	55012118	2		RISORCENTRICO ANNOILAG		LEISTUNG		TRABEIT
18	03245101	4		VITI SOLLAZIONI		VITI		SCHRAUBEN
19	03366300	4		ROSELE MULTI		ROSDREH		WASSEL
20	30060425	1		ROSELE BASIS		ROSDREH		WASSEL
21	23250036	1		CHIAVILLI SOLLAZIONI		HEBELN		HEBELN
22	03226001	3		VITI SOLLAZIONI		VITI		SCHRAUBEN
23	30322074	1		ROSELE MULTI		ROSDREH		WASSEL
24	03230501	4		VITI SOLLAZIONI		VITI		SCHRAUBEN
25	03385401	4		ROSELE SCELLE		ROSDREH		WASSEL
26	30060427	1		CHIAVILLI KASTEN		HEBELN		HEBELN
27	30322075	1		ROSELE MULTI		ROSDREH		WASSEL
28	03220401	9		VITI SOLLAZIONI		VITI		SCHRAUBEN
29	03383311	5		ROSELE SCELLE		ROSDREH		WASSEL
30	30060432	1		CHIAVILLI KASTEN		HEBELN		HEBELN
31	30322076	1		ROSELE MULTI		ROSDREH		WASSEL
32	03383201	4		ROSELE SCELLE		ROSDREH		WASSEL
33	30060480	1		CHIAVILLI KASTEN		HEBELN		HEBELN
34	03709010	1		ROSELE (QUANTITÀ) SOLLAZIONI (QUANTITÀ) KASTEN (QUANTITÀ)		ROSDREH (QUANTITÀ) WASSEL (QUANTITÀ) HEBELN (QUANTITÀ)		ROSDREH (QUANTITÀ) WASSEL (QUANTITÀ) HEBELN (QUANTITÀ)



- ① SERBATOI CARBURANTE
- ⓕ RESERVOIR CARBURANT
- ⓖ FUEL TANK
- ⓓ KRAFTSTOFFTANK

TAV. 01-02
96010150

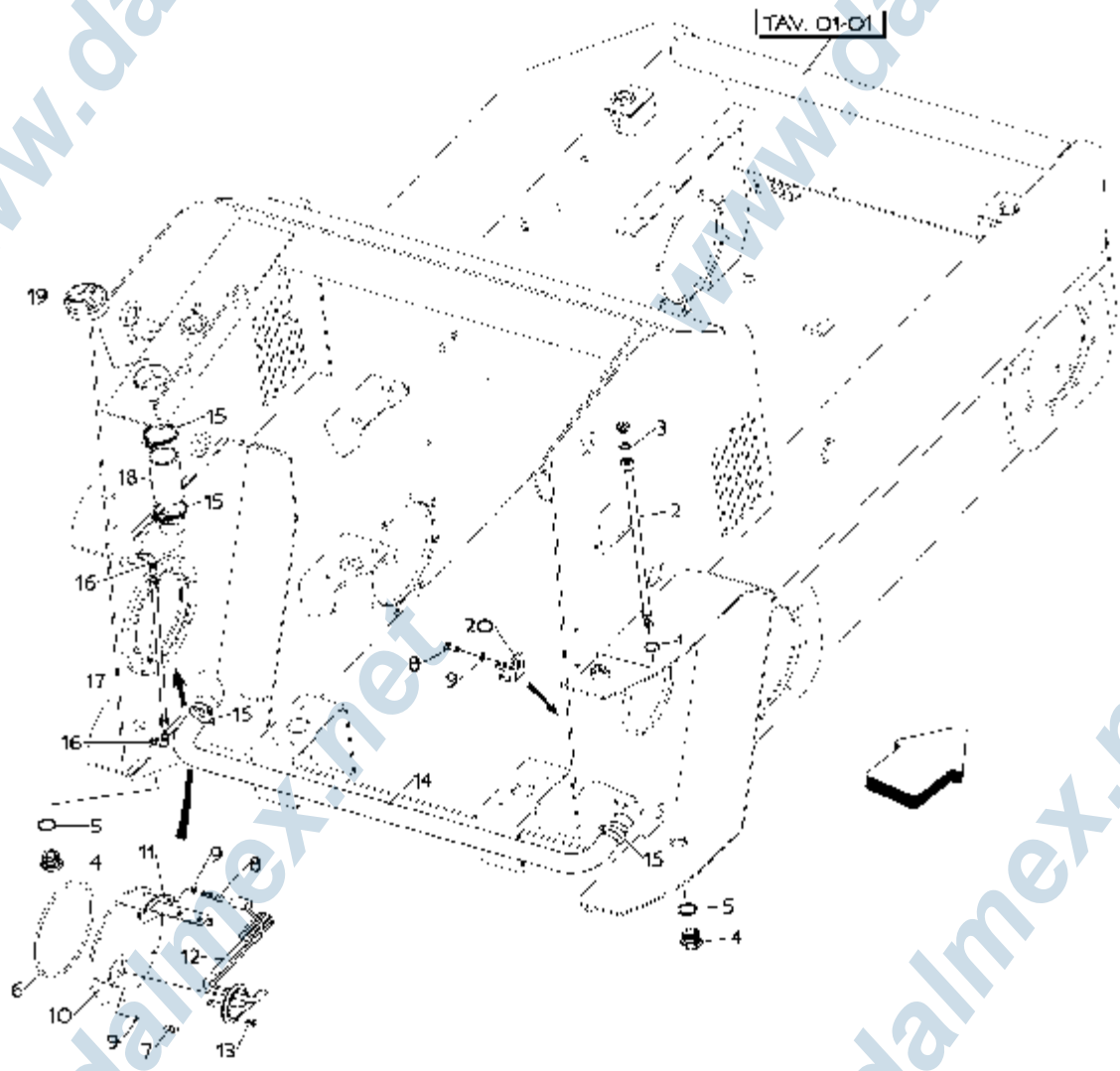



Tav. 01-02 - 96010150

P.	Codice	Q.	Ⓐ Ⓑ Denominazione Benennung	Ⓕ Description	Ⓖ Description
1	03168400	1	GAJRN / ONI DICI LINES	GAJRN LIR	GAJRN L
2	25160356	1	LIRI RORI	LIRI	R-LI
3	03840027	1	SALIC LNF LIRI L	SOL-PIRAM	LIR MILLER
4	13160039	2	APPD STOP EN	LOCUD OK	L-LIG
5	03168000	2	GAJRN / ONI DICI LINES	GAJRN LIR	GAJRN L
6	03491002	1	ANILICODI DIR RINES	ANIL AUO ?	DIR RINES
7	03230301	6	VI SOL ROUR	VIS	SOL R
8	03230501	3	VI SOL ROUR	VIS	SOL R
9	03385050	9	ROSI LA SOL LI	IRON DILL	WASIT ?
10	15100690	1	COU RICH D OK	COU RICH	COU RING
11	45152476	1	SUPPORIC LAL L RUNG	SUPPOR ?	SU-LOR
12	03841609	1	L V LICO GARDI RAN L KIRI S O S AND	NEW AJ GARDI RAN L	L L L V
13	03207690	6	VI SOL ROUR	VIS	SOL R
14	25170102	1	LIRI RORI	LIRI	R-LI
15	13570400	4	LASCI LA SOL LI	WNI	O WPI
16	33882200	2	RACORIC ANCI LUS	ANCI O R	CONN O R
17	25170052	1	L V LICO GARDI O GARDI S AND	NEW AJ GARDI O	L L L V
18	25170104	1	LIRI RORI	LIRI	R-LI
19	03841205	1	APPD STOP EN	LOCUD OK	L-LIG
20	45152557	1	SUPPORIC LAL L RUNG	SUPPOR ?	SU-LOR



- Ⓛ PORTELLONE
- ⓕ PORTE MOTEUR
- Ⓞ ENGINE FLAP
- ⓓ MOTORLUKE

TAV. 01-03
96010151

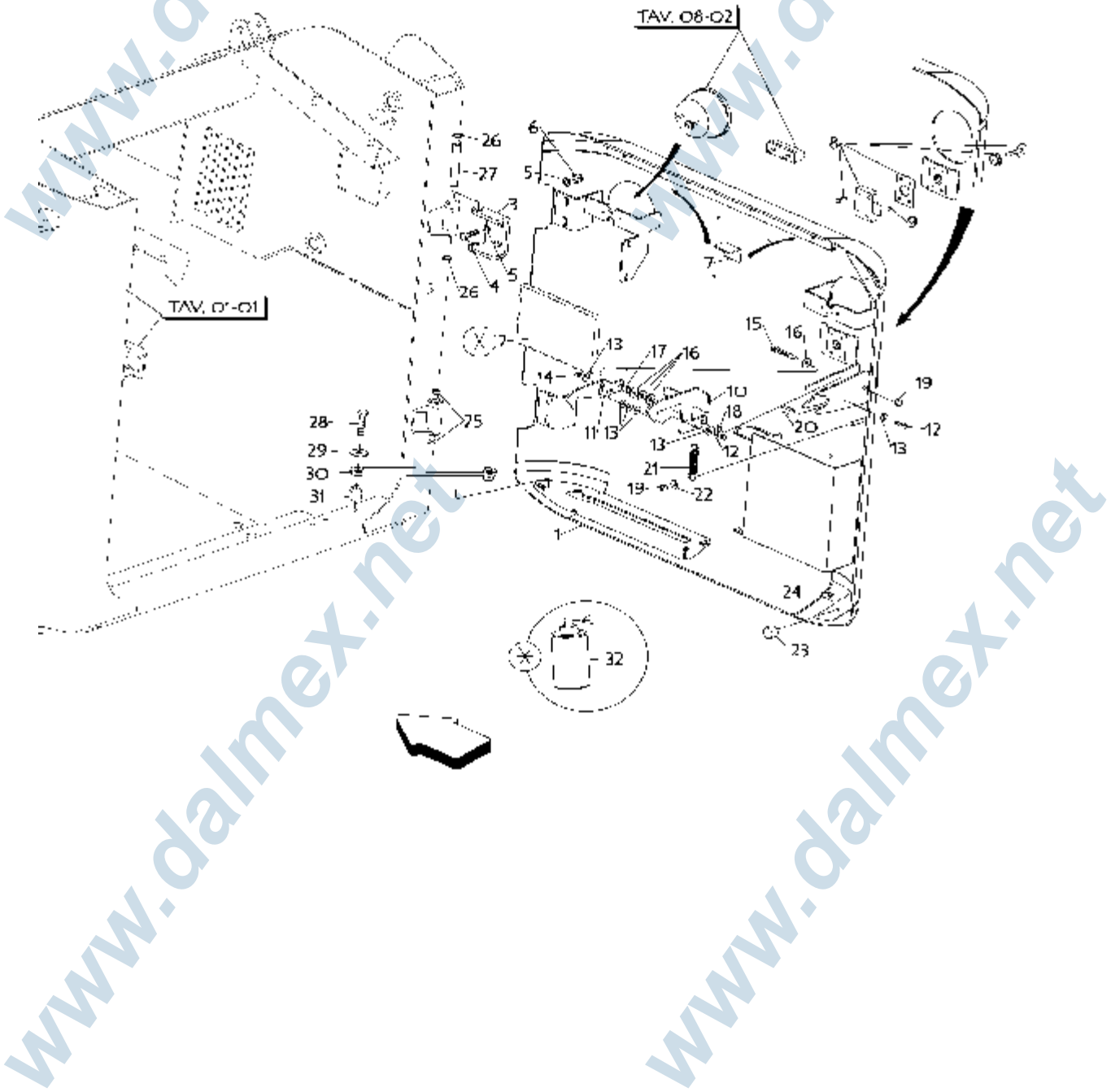

Tav. 01-03 - 96010151

P.	Codice	Q.	Ⓐ Ⓑ	Denominazione Benennung	Ⓔ	Description	ⒼⒸ	Description
1	30013483	1		FORNITORE MOTORI DI BOMBARDIERE		FORNITORE		ENGINE TAP
2	30320119	1		ROSALE ROSALE		ROSALE		ROSALE
3	95C50105	2		GRANDE ROSALE		GRANDE		ROSALE
4	03240602	4		ROSALE		ROSALE		ROSALE
5	03386050	3		ROSALE		ROSALE		ROSALE
6	03366300	4		ROSALE		ROSALE		ROSALE
7	30320258	2		GRANDE ROSALE		GRANDE		ROSALE
8	03572025	1		ROSALE		ROSALE		ROSALE
9	03207400	4		ROSALE		ROSALE		ROSALE
10	95100044	1		ROSALE		ROSALE		ROSALE
11	95100054	1		ROSALE		ROSALE		ROSALE
12	03220701	2		ROSALE		ROSALE		ROSALE
13	03383202	6		ROSALE		ROSALE		ROSALE
14	03364010	1		ROSALE		ROSALE		ROSALE
15	03234601	1		ROSALE		ROSALE		ROSALE
16	03385600	4		ROSALE		ROSALE		ROSALE
17	45020165	1		ROSALE		ROSALE		ROSALE
18	95100060	1		ROSALE		ROSALE		ROSALE
19	03365100	2		ROSALE		ROSALE		ROSALE
20	95100059	1		ROSALE		ROSALE		ROSALE
21	03732100	1		ROSALE		ROSALE		ROSALE
22	03385601	1		ROSALE		ROSALE		ROSALE
23	03520305	2		ROSALE		ROSALE		ROSALE
24	03365001	2		ROSALE		ROSALE		ROSALE
25	33593658	4		ROSALE		ROSALE		ROSALE
26	03420016	4		ROSALE		ROSALE		ROSALE
27	95C50106	2		ROSALE		ROSALE		ROSALE
28	03250701	1		ROSALE		ROSALE		ROSALE
29	03387305	1		ROSALE		ROSALE		ROSALE
30	95100056	1		ROSALE		ROSALE		ROSALE
31	45070823	1		ROSALE		ROSALE		ROSALE
32	03709010	1		ROSALE		ROSALE		ROSALE



- Ⓛ GRUPPI RUOTE
- Ⓛ GROUPE ROUES
- Ⓛ WHEELS GROUP
- Ⓛ RAEDERGRUPPE

TAV. 02-01

96020098

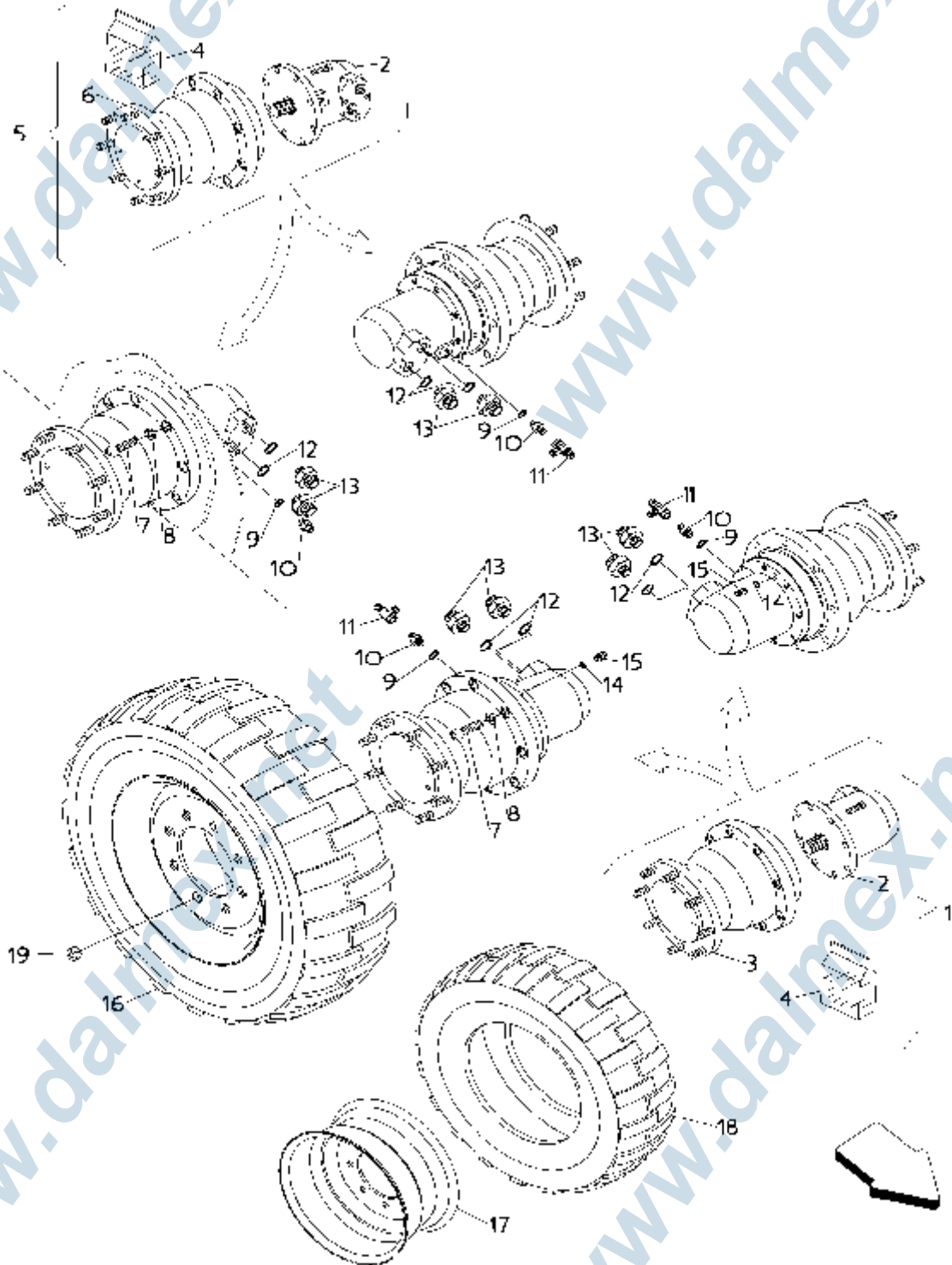



Tav. 02-01 - 96020098

P.	Codice	Q.	① ② Denominazione Benennung	③ Description	④ Description
1	03821034	2	MOTORIUTTOR CENTRIFUGO CO?	MOTOR DUC. UR	GEAR MOTOR
2	63790400	4	MOTOR MO CO?	VO. UR	MOTOR
3	62821000	2	RIELI COI UNITRE 12JUG889 TRIERI	RIELI COI	RIELI COI UNIT
4	62498407	4	K. COUPLINGEAGGROPPAMETIC SALV. DIST. JMG. NLU. R. KL. P. UR.	K. COUPL. UR. D. COUPLAGE	KIT COUPLER GASKI
5	03821035	2	MOTORIUTTOR CENTRIFUGO CO?	MOTOR DUC. UR	GEAR MOTOR
6	62821001	2	RIELI COI UNITRE 12JUG889 TRIERI	RIELI COI	RIELI COI UNIT
7	03264500	32	VII SOL. RAU. R.	VII	SOIL WA.
8	03388000	32	ROSE. TA SOL. TA	ROSE. TA	WASH. T.
9	03168500	4	GIAMBI / ONI DICI. URES	GIAMBI UR	GASK. T.
10	13152700	4	RACCORDO ANSO. L. USS.	RACCORDO	CONNECTION
11	03631700	3	RACCORDO ANSO. L. USS.	RACCORDO	CONNECTION
12	03168400	8	GIAMBI / ONI DICI. URES	GIAMBI UR	GASK. T.
13	13154000	8	RACCORDO ANSO. L. USS.	RACCORDO	CONNECTION
14	03160012	2	GIAMBI / ONI DICI. URES	GIAMBI UR	GASK. T.
15	13150402	2	RACCORDO ANSO. L. USS.	RACCORDO	CONNECTION
16	03101604	4	RUCLE RADO	RUCLE	GEAR ROCK RIM
17	62104009	4	GE. RE. TIC E. T. GI	GE. RE. TIC	GEAR RING
18	62101702	4	COPI. ETURA R. T. EN. D. COI	COPI. ETURA	COUPLER
19	03368320	32	CA. CO MULTI. R.	CA. CO	MULTI



- Ⓛ MOTORE DIESEL
- Ⓜ MOTEUR DIESEL
- Ⓝ DIESEL ENGINE
- Ⓞ DIESEL MOTOR

TAV. 03-01
96030073

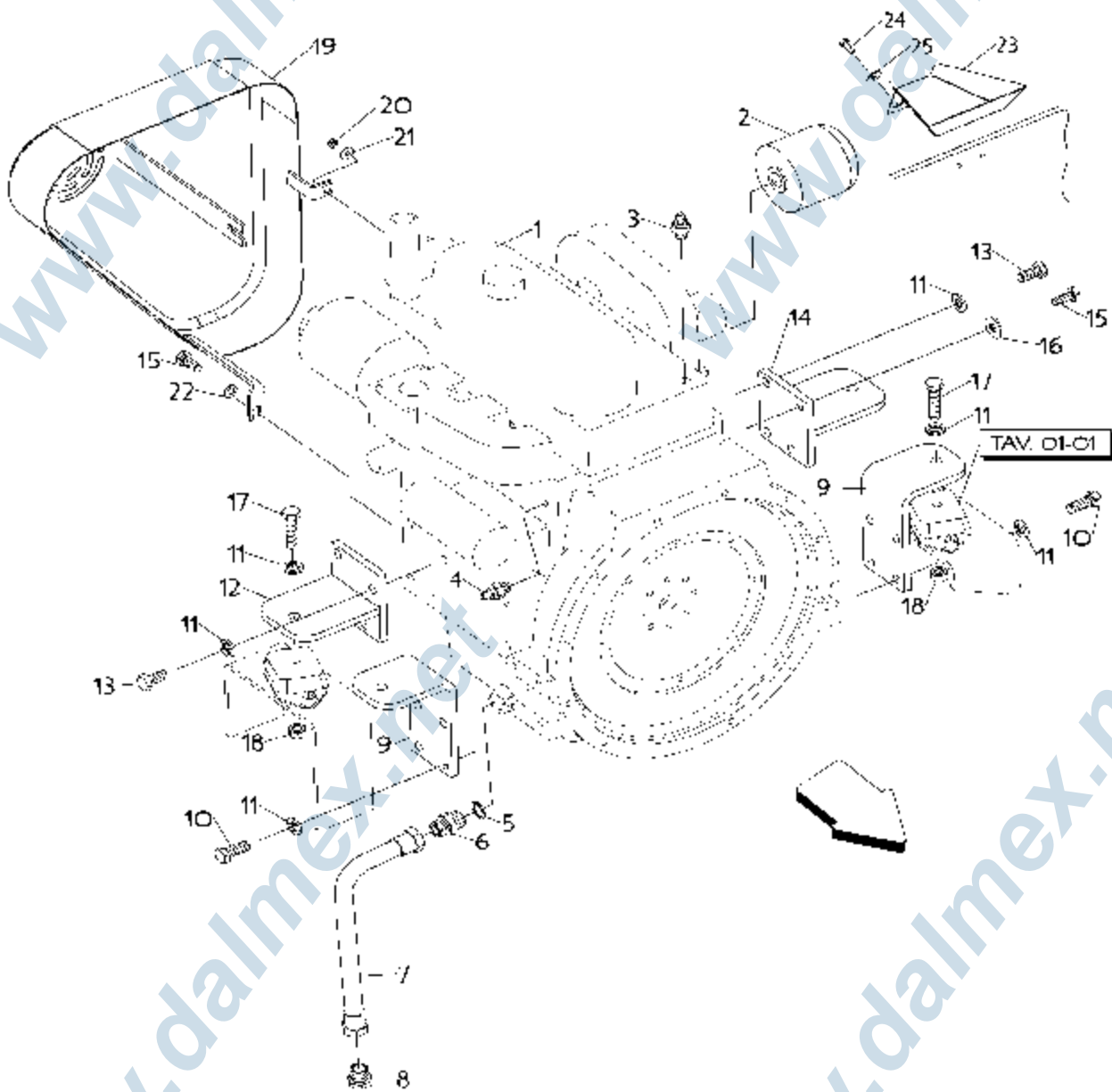

Tav. 03-01 - 96030073

P.	Codice	Q.	Ⓐ Ⓑ Denominazione Benennung	Ⓕ Description	Ⓖ Description
1	03006018	1	MOTOR MOTOR	MOTOR	MOTOR
2	62007417	1	CARBUCCIO DI CILINDRO /	CARBURETOR	CARBURETOR
3	62008250	1	BULLONE M6 X 100 WASHER M6 X 100	BOLT M6 X 100 WASHER M6 X 100	WASHER M6 X 100
4	62008225	1	BULLONE M6 X 100 CILINDRO	BOLT M6 X 100	BOLT M6 X 100
5	03168410	1	VALVOLA DIESEL	VALVE	VALVE
6	13153910	1	RAFFREDDO ANSCHESS	COOLER	COOLER
7	03131300	1	OLIO ROVERE	OIL	OIL
8	13166000	1	VALVOLA STOP IN	VALVE	VALVE
9	20051198	2	FILTRO OLIO	FILTER	FILTER
10	03257500	3	VITE SERRATURA	SCREW	SCREW
11	03387300	19	ROVESCIA SCELTA	FLYWHEEL	WASHER
12	20051202	1	FILTRO OLIO	FILTER	FILTER
13	03250210	7	VITE SERRATURA	SCREW	SCREW
14	20051199	1	FILTRO OLIO	FILTER	FILTER
15	03247800	2	VITE SERRATURA	SCREW	SCREW
16	03386600	1	ROVESCIA SCELTA	FLYWHEEL	WASHER
17	03250602	4	VITE SERRATURA	SCREW	SCREW
18	03367001	4	VALVOLA MUTTER	VALVE	NUT
19	30013277	1	VALVOLA KASHEIN	VALVE	CRANKCASE
20	03364001	1	VALVOLA MUTTER	VALVE	NUT
21	03383311	1	ROVESCIA SCELTA	FLYWHEEL	WASHER
22	03386050	1	ROVESCIA SCELTA	FLYWHEEL	WASHER
23	55012190	1	SCAVINCO CILINDRO	EXHAUST	CYLINDER
24	03220401	2	VITE SERRATURA	SCREW	SCREW
25	03383201	2	ROVESCIA SCELTA	FLYWHEEL	WASHER



- Ⓜ MOTORE DIESEL: POMPE - ACCOPPIATORE
- Ⓜ MOTEUR DIESEL: POMPE - COUPLAGE
- Ⓜ DIESEL ENGINE: PUMP - COUPLER
- Ⓜ DIESEL MOTOR: PUMPE - KUPPLUNGSSCHLAUCH

TAV. 03-02
96030074

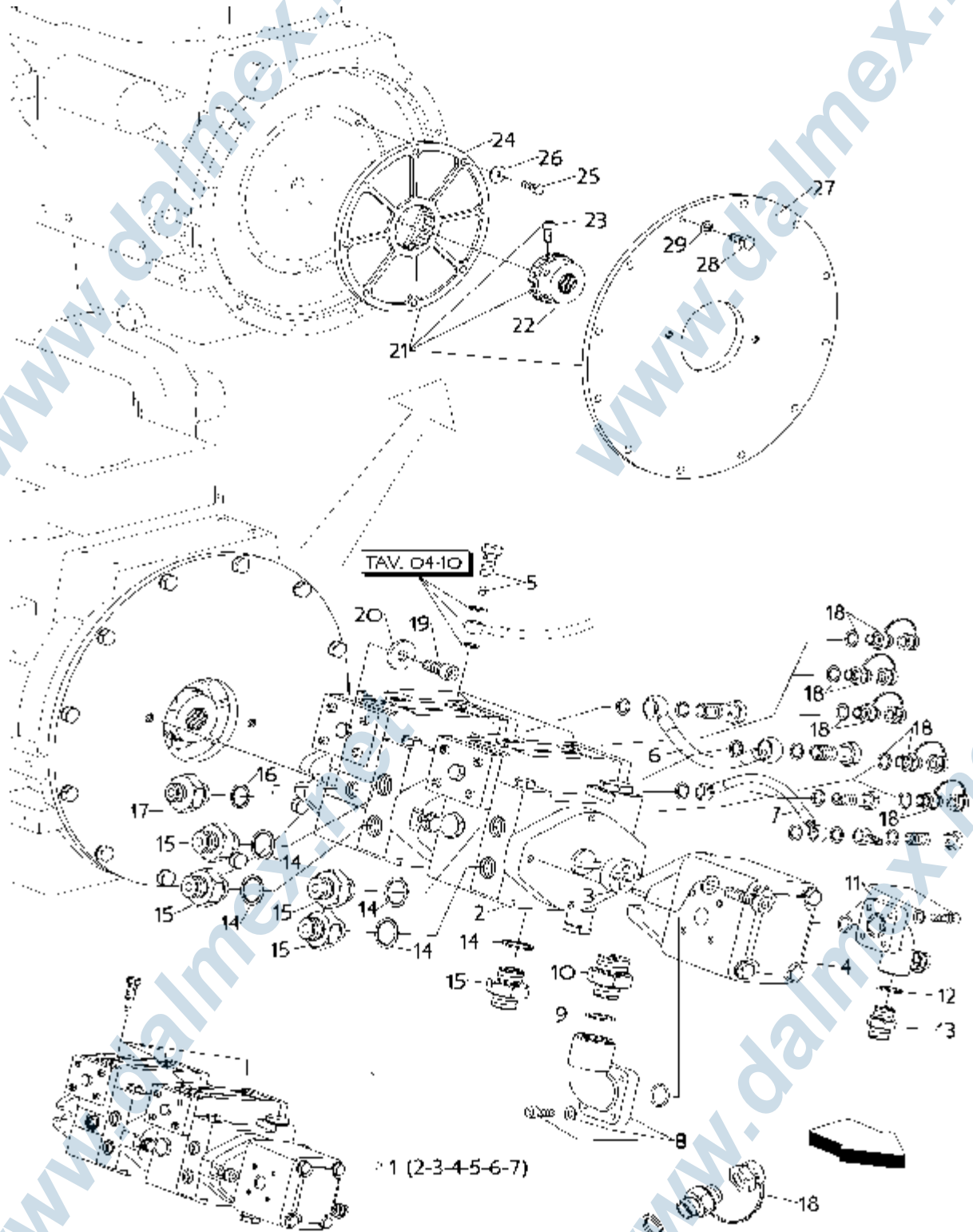



Tav. 03-02 - 96030074

P.	Codice	Q.	Ⓐ Ⓑ Denominazione Benennung	Ⓔ Description	ⒼⒸ Description
1	03790088	1	FOV-PA-COMP-1A VO KOMP NI PLVFI	-COMPI GOV-PI	COMPPI PLMP
2	62790001	1	FOV-PA PUMP	-COMPI	PJVP
3	62799601	1	MANGIOLO MULI	MANGIOLO	SHLVI
4	62795001	1	FOV-PA PUMP	-COMPI	PJVP
5	62797004	4	VII SCELTAU NI	VIS	SEK Vv
6	62123401	1	URTO ROTTI NI	JYAL	P-PI
7	62123400	1	URTO ROTTI NI	JYAL	P-PI
8	03616710	1	RACCORDO ANSO I LSS	ANSO I LSS	CONNEZION
9	03168000	1	GIUNTI / ONI DIECI UNO	GIUNTI JIR	GIUNTI
10	13154100	1	RACCORDO ANSO I LSS	ANSO I LSS	CONNEZION
11	03611300	1	RACCORDO ANSO I LSS	ANSO I LSS	CONNEZION
12	03168400	1	GIUNTI / ONI DIECI UNO	GIUNTI JIR	GIUNTI
13	13152900	1	RACCORDO ANSO I LSS	ANSO I LSS	CONNEZION
14	03160008	5	GIUNTI / ONI DIECI UNO	GIUNTI JIR	GIUNTI
15	13153000	5	RACCORDO ANSO I LSS	ANSO I LSS	CONNEZION
16	03160006	1	GIUNTI / ONI DIECI UNO	GIUNTI JIR	GIUNTI
17	13154000	1	RACCORDO ANSO I LSS	ANSO I LSS	CONNEZION
18	13840012	5	PIV SOTTO CONTROLLO KONTROLLKLEPUNG	PIV SOTTO CONTROLLO	CHILDRING COUPLING
19	03254700	2	VII SCELTAU NI	VIS	SEK Vv
20	03387305	2	ROSI LA SCHLITZ	RONDELLI	WASHER
21	13520016	1	ACCOPPIATORI KUPPLINGSNO II AUGI	COUPLER	COUPLER
22	63528401	1	MORZO NANI	MEZZI	FLUT
23	03234801	1	VII SCELTAU NI	VIS	SEK Vv
24	62529604	1	GIUNTO KUPPLING	GIUNTI	GIUNTI
25	03237560	3	VII SCELTAU NI	VIS	SEK Vv
26	03385600	3	ROSI LA SCHLITZ	RONDELLI	WASHER
27	63528202	1	FRANGIA FRANSCIT	FRANGIA	FRANGIA
28	03247500	12	VII SCELTAU NI	VIS	SEK Vv
29	03386050	12	ROSI LA SCHLITZ	RONDELLI	WASHER



- Ⓛ MOTORE DIESEL: TUBI CARBURANTE
- Ⓧ MOTEUR DIESEL: TUYAU DL CARBURANT
- Ⓞ DIESEL ENGINE: FUEL PIPES
- Ⓛ DIESEL MOTOR: TREIBSTOFFROHREN

TAV. 03-03
96030075

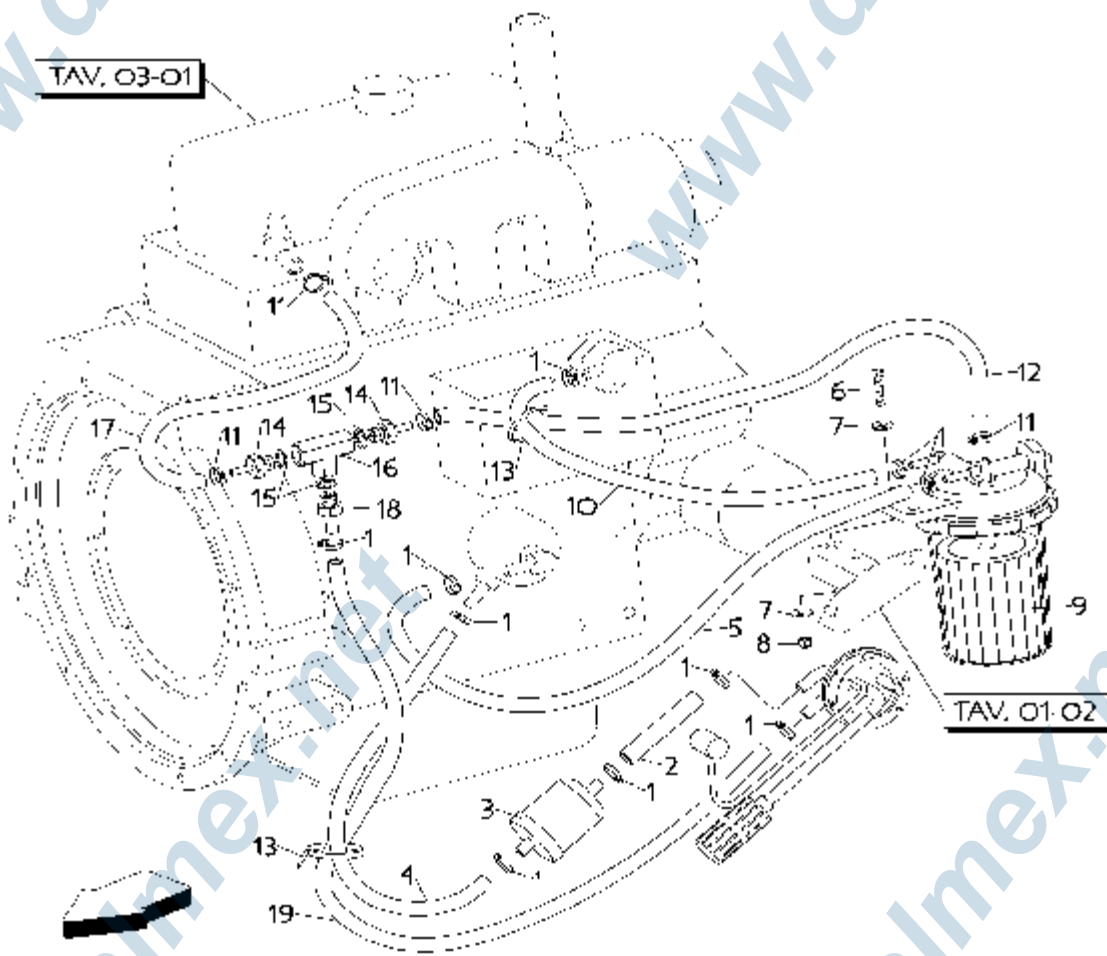



Tav. 03-03 - 96030075

P.	Codice	Q.	① ② Denominazione Benennung	③ Description	④ Description
1	13577901	10	FASCIA SCHELE	WIND	C AWP
2	25170070	1	URO ROTTI	JYAL	F-PI
3	03007200	1	FILTRO FILTER	R	III 2
4	25170096	1	URO ROTTI	JYAL	F-PI
5	25170097	1	URO ROTTI	JYAL	F-PI
6	03220800	2	VIT SCIRIAMI	VIS	SCIRI AM
7	03383201	4	ROTTI SCHELE	RONDELLI	WASHER
8	03364010	2	FASSO MUTTER	CIRCU	NUT
9	62007229	1	FILTRO FILTER	R	III 2
10	25170098	1	URO ROTTI	JYAL	F-PI
11	13572701	4	FASCIA SCHELE	WIND	C AWP
12	25170100	1	URO ROTTI	JYAL	F-PI
13	13577500	2	FASCIA SCHELE	WIND	C AWP
14	33143500	2	RACCORDO ANSCHIANS	SAOCCO RI	CONNECTION
15	03168500	3	GIUNTA / ONI DIECI UNO	GIUNTA	GASKET
16	03630300	1	GIUNZIONE VITIBONDING	ANSCHIANS	JUNCTION
17	25170099	1	URO ROTTI	JYAL	F-PI
18	33140017	1	RACCORDO ANSCHIANS	SAOCCO RI	CONNECTION
19	25170101	1	URO ROTTI	JYAL	F-PI

- ① MOTORE DIESEL: COMANDO ACCELERATORE
- ② MOTEUR DIESEL: COMMANDE ACCELERATEUR
- ③ DIESEL ENGINE: THROTTLE CONTROL
- ④ DIESEL MOTOR: BESCHLEUNIGER STEUERUNG

TAV. 03-04
96030076

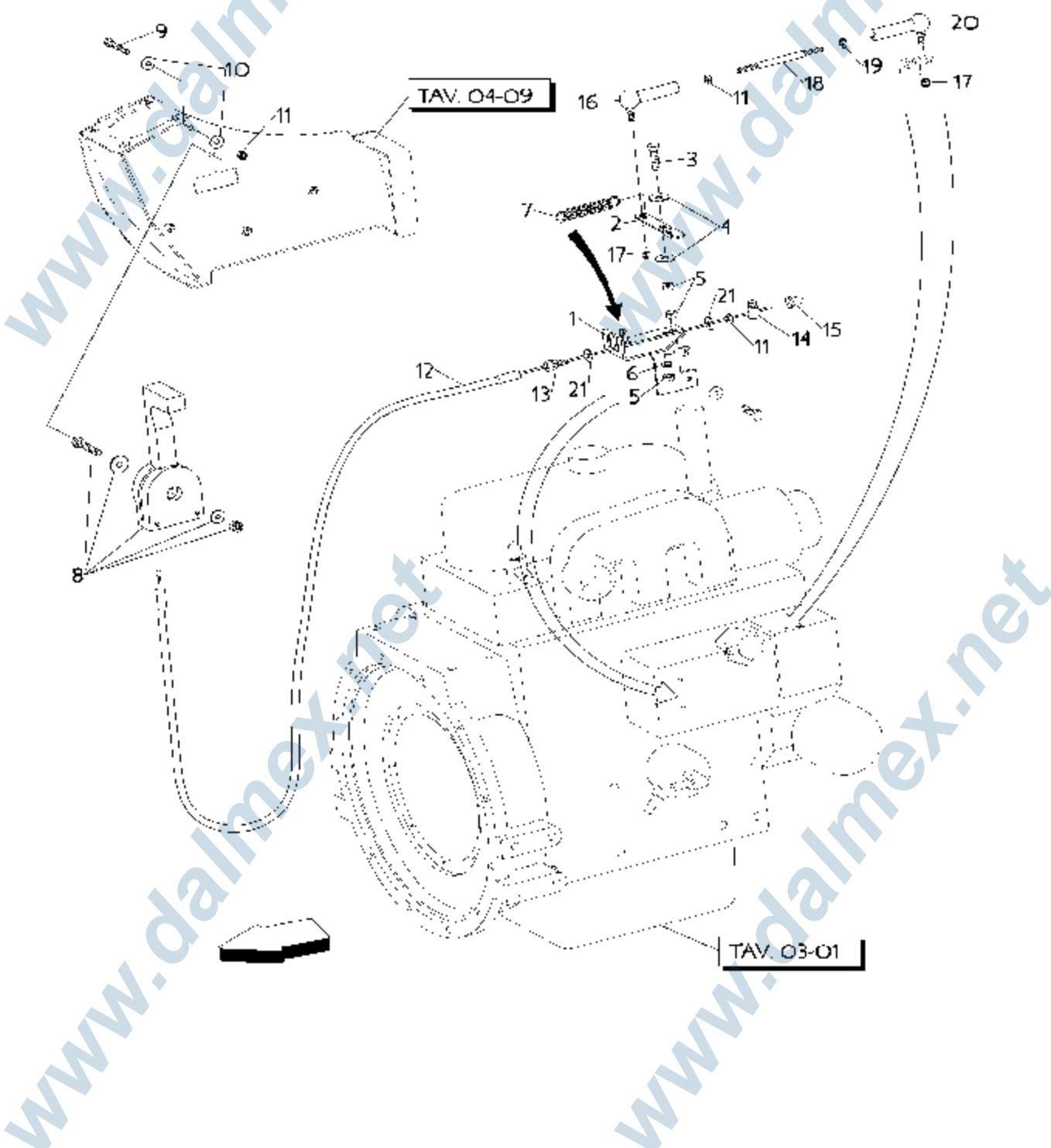



Tav. 03-04 - 96030076

P.	Codice	Q.	① ②	Denominazione Benennung	③	Description	④	Description
1	45152129	1		SUPPORTO LAVORAZIONE		SUPPORTO		SUP-038
2	50100948	1		PISTOLA PER JET		PISTOLA		CONNECTING ROD
3	03230701	1		VITE		VITE		SCREW
4	03385600	2		SCALARE ROSELEA SCHELEA		ROSDREH		WASHER
5	03365001	3		DAVOLI MUTTER		DRUCK		NUT
6	03385000	1		ROSELEA SCHELEA		ROSDREH		WASHER
7	03732010	1		MORSA LAVORAZIONE		DRUCKZUG		SPANNER
8	03563103	1		MANTUINO LAVORAZIONE		MANTEL		HANDCOVER
9	03220901	1		VITE		VITE		SCREW
10	03383201	2		SCALARE ROSELEA SCHELEA		ROSDREH		WASHER
11	03364001	3		DAVOLI MUTTER		DRUCK		NUT
12	03560500	1		CAVOC KAPPE		DRUCK		COVER
13	03563000	1		REGOLATORE ZUGGELEITER		REGELGER		ADJUSTER
14	03563800	1		MORSALE LAVORAZIONE		DRUCK		CLAMP
15	03460610	1		TERMINAZIONE KABELSCHLEIF		DRUCKSTRECKGER		PIPINGRING
16	03554000	1		SNOCIO GELINK		DRUCK		ATTACHMENT
17	03364010	2		DAVOLI MUTTER		DRUCK		NUT
18	50101107	1		TRAVI GELANDE		TRAVI		TRUCK
19	03364002	1		DAVOLI LINKSMUTTER		DRUCKGAUGE II		NUT
20	03554001	1		SNOCIO LINKSGELINK		DRUCKGAUGE II		LEFT SIDE LINK
21	03383311	2		ROSELEA SCHELEA		ROSDREH		WASHER



- Ⓘ MOTORE DIESEL: ASPIRAZIONE - SCARICO
- Ⓕ MOTEUR DIESEL: ASPIRATION ET ECHAPPEMENT
- ⒼⒷ DIESEL ENGINE SUCTION AND EXHAUST
- Ⓓ DIESEL MOTOR ZUG UND AUSLASS

TAV. 03-05
96030092

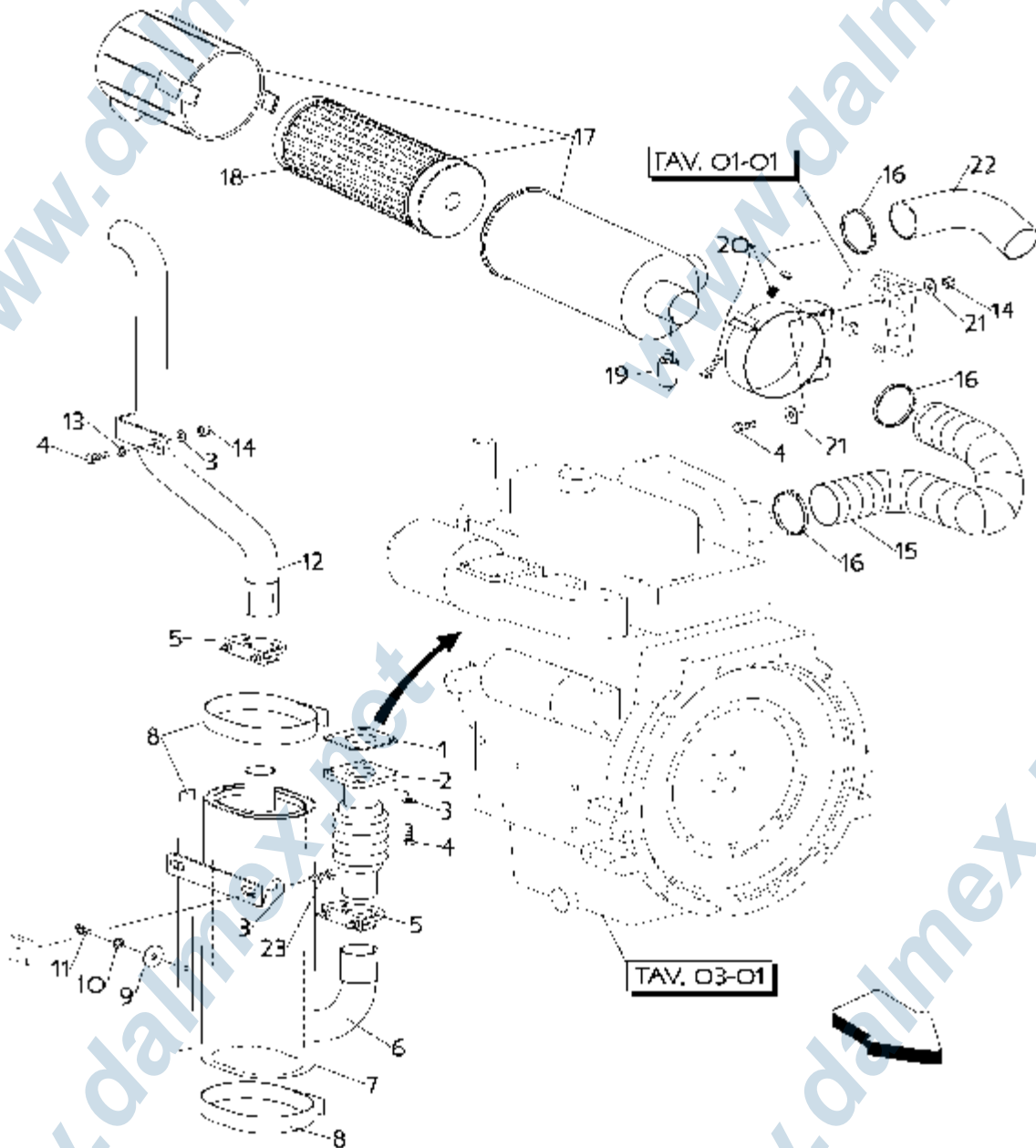



Tav. 03-05 - 96030092

P.	Codice	Q.	Ⓐ Ⓑ Denominazione Benennung	Ⓔ Description	Ⓖ Description
1	62009107	1	GIUNTA / ONI DICHI LINEA	GRABER	GRABER
2	03009637	1	COLLETTOR KOLLEKTOR	COLLECTOR	COLLECTOR
3	03385050	7	ROSETTA SCHLEIF	RONDELLE	WASLER
4	03230601	7	VITI SCHRAUBEN	VIS	SEKRAUBEN
5	13570020	2	COLLETTOR BUNDRING	COLLECTOR	COLLECTOR
6	03009636	1	MARMETTA SCHWELBEN	POURTECH-HEBENT	MULLER
7	20051234	1	FILTRAZIONE SCHLEIF	FILTRATION	FILTRATION
8	20051267	1	VALVOLA DISCO KLEBENDE	ADVALEDISK	ADVALEDISK
9	03385301	2	ROSETTA SCHLEIF	RONDELLE	WASLER
10	03385000	2	ROSETTA SCHLEIF	RONDELLE	WASLER
11	03230301	2	VITI SCHRAUBEN	VIS	SEKRAUBEN
12	03009638	1	TERMINA ANSCHLUSSE	JUSTIZCHAPPMENT	EXJUSTMULLER
13	03385201	1	ROSETTA SCHLEIF	RONDELLE	WASLER
14	03365100	3	VALVOLA MULLER	DISK	NULL
15	03009642	1	VALVOLA MULLER	DISK	DISK
16	13577201	3	VALVOLA SCHLEIF	DISK	DISK
17	03007011	1	FILTRAZIONE FILTRE	FILTRATION	AIRFILTER
18	62007058	1	CARTELLA FILTRE	CARTRIDGE	CARTRIDGE
19	03007006	1	INDICAZIONE ANSALE	INDICAZIONE	INDICAZIONE
20	03007012	1	COLLETTOR BUNDRING	COLLECTOR	COLLECTOR
21	03385600	4	ROSETTA SCHLEIF	RONDELLE	WASLER
22	03009649	1	MANGHIO MULLER	MANGON	SEKRAUBEN
23	03230501	2	VITI SCHRAUBEN	VIS	SEKRAUBEN



- Ⓜ MOTORE DIESEL: RAFFREDDAMENTO
- Ⓜ MOTEUR DIESEL: REFRROIDISSEMENT
- Ⓜ DIESEL ENGINE: COOLING SYSTEM
- Ⓜ DIESEL MOTOR: KUEHLUNG

TAV. 03-06
96030090

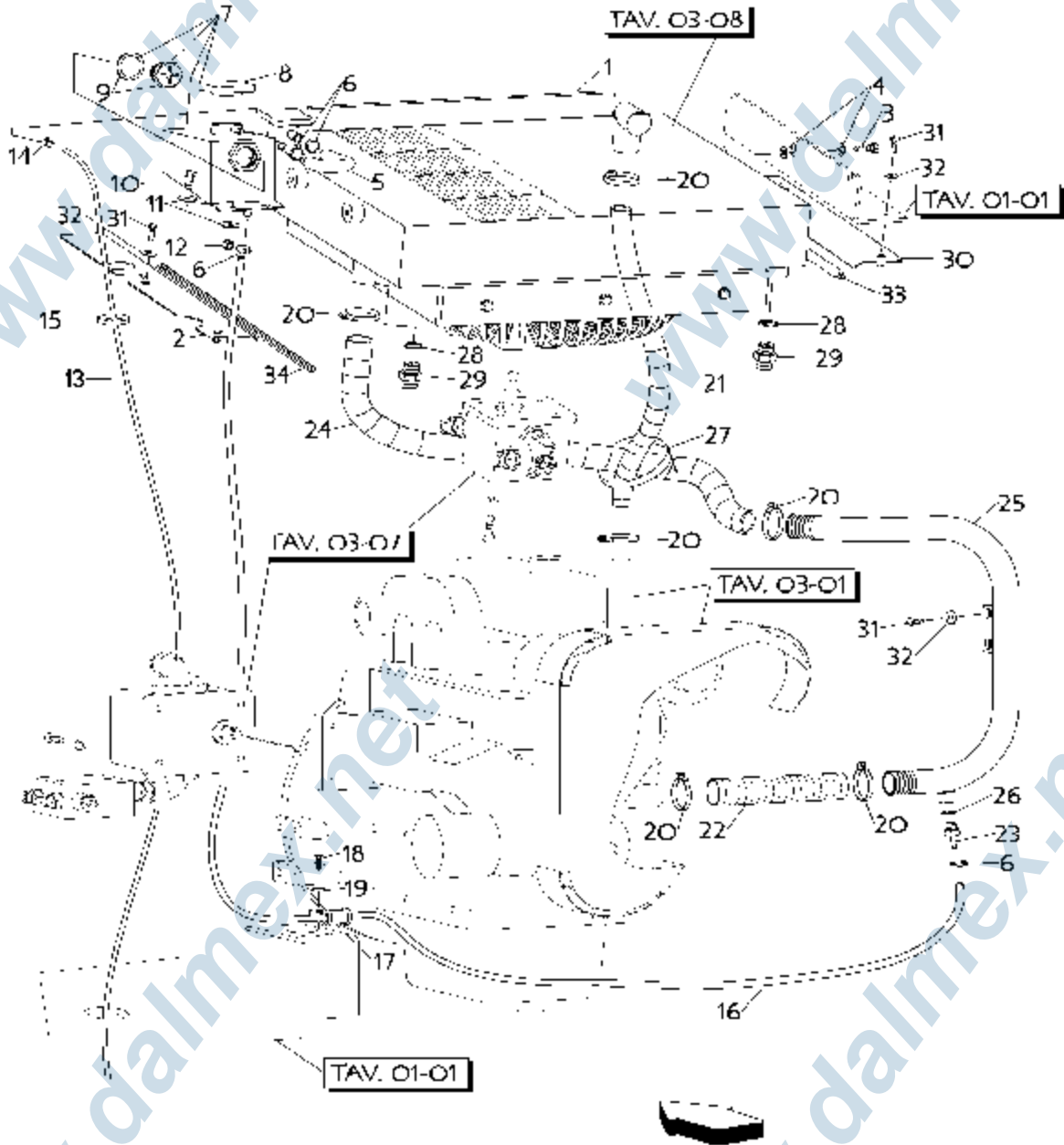

www.dalmex.net

Tav. 03-06 - 96030090

P.	Codice	Q.	Ⓐ Ⓑ	Denominazione Benennung	Ⓔ	Description	ⒼⒷ	Description
1	30320257	1		REG AMINICO RODA ION		RODA ION		RODA ION
2	30013441	1		FA RA A SCHIEI		CHIE ION		BUKIL I AD
3	03230601	4		VI		VIS		SCRE VE
4	03385201	4		SCI RAU R ROSI TA SCHIEI		RON DILLI		WASIL I ?
5	27200303	1		UIO ROU R		JYAL		F-PI
6	13577900	4		FASCI TA SCHIEI		WNI		O AWP
7	33842611	1		WASCI TA WASCI KAST N		OU R		SMALL TANK
8	64840500	1		A-20 STOP EN		ROU I ON		-I JG
9	72842204	1		I V ILO SIANI		NIW AJ		LI VIT
10	03230501	3		VI SCI RAU R		VIS		SCRE VE
11	03385600	4		ROSI TA SCHIEI		RON DILLI		WASIL I ?
12	03365100	3		DA IO MUTTER		CHIO		NLI
13	27200306	1		UIO ROU R		JYAL		F-PI
14	13577800	1		FASCI TA SCHIEI		WNI		O AWP
15	13577500	1		FASCI TA SCHIEI		WNI		O AWP
16	27200305	1		UIO ROU R		JYAL		F-PI
17	13572414	1		COILAR BUNDING		COIL I R		COILAR
18	03220401	1		VI SCI RAU R		VIS		SCRE VE
19	03383202	1		ROSI TA SCHIEI		RON DILLI		WASIL I ?
20	13577300	3		FASCI TA SCHIEI		WNI		O AWP
21	27200307	1		UIO ROU R		JYAL		F-PI
22	27200330	1		UIO ROU R		JYAL		F-PI
23	33143505	1		RACCORDO ANSO I LUS		ACCORD		CONNECTION
24	27200329	1		UIO ROU R		JYAL		F-PI
25	27200326	1		GLI NA ROU R SCHIEI /		GAMI		PLAT
26	03168500	1		GLI NA / ONI DICI I URE		GLI NA I R		GLI NA I
27	13572202	1		FASCI TA SCHIEI		WNI		O AWP
28	03168000	2		GLI NA / ONI DICI I URE		GLI NA I R		GLI NA I
29	13153000	2		RACCORDO ANSO I LUS		ACCORD		CONNECTION
30	30013440	1		FA RA A SCHIEI		CHIE I ON		BUKIL I AD
31	03220601	6		VI SCI RAU R		VIS		SCRE VE
32	03383201	6		ROSI TA SCHIEI		RON DILLI		WASIL I ?
33	30320271	1		GLI NA / ONI DICI I URE		GLI NA I R		GLI NA I
34	30320270	1		GLI NA / ONI DICI I URE		GLI NA I R		GLI NA I

- Ⓢ MOTORE DIESEL: IMP. OLEODIN. RAFFREDDAMENTO
- Ⓢ MOTEUR DIESEL: INSTALL. OLEODYN. DE REFROIDISSEMENT
- Ⓢ DIESEL ENGINE: COOLING HYDRAULIC SYSTEM
- Ⓢ DIESEL MOTOR: HYDRALLISCHE KUEHLINGSANLAGE

TAV. 03-07
96030079

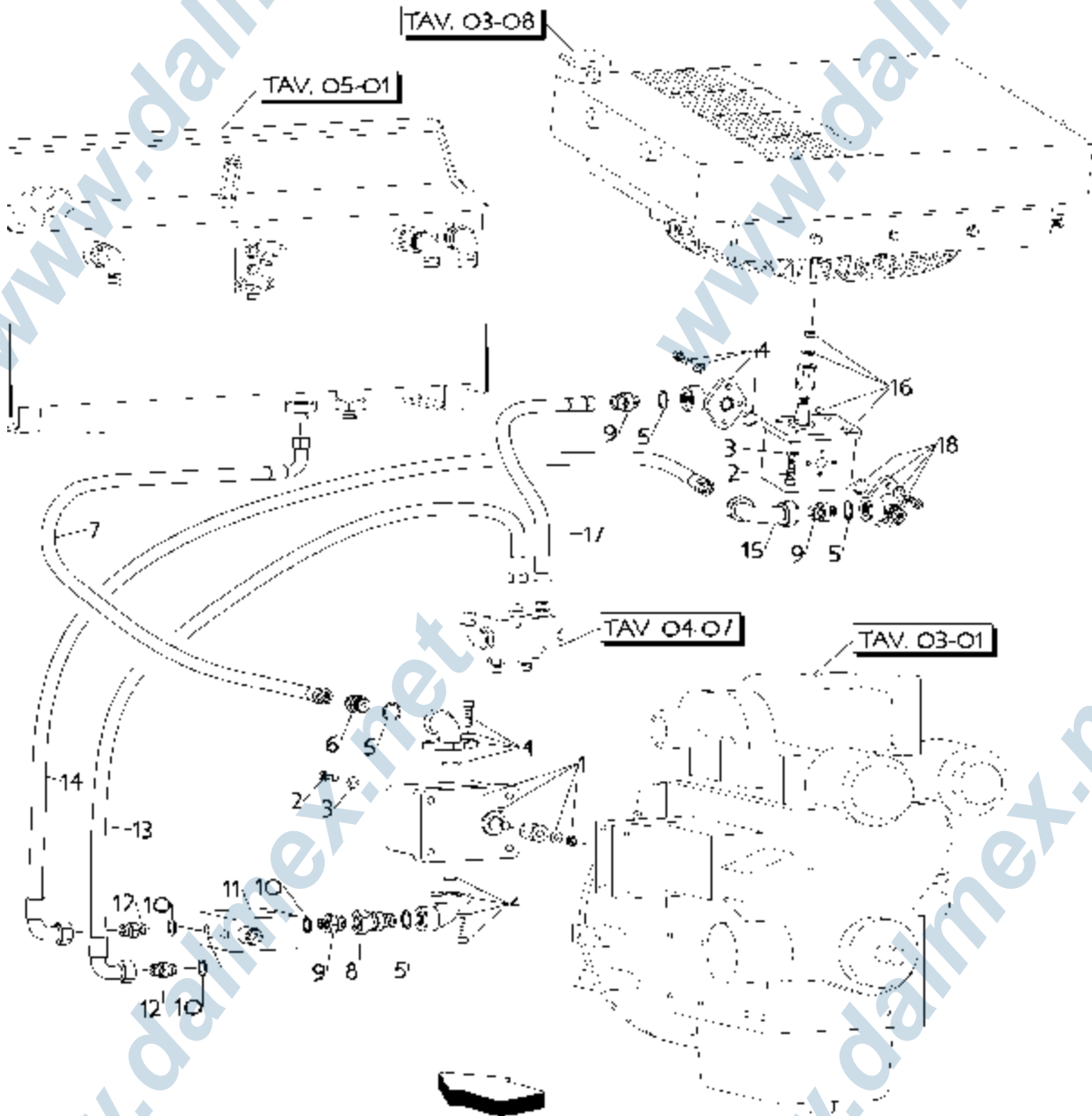



Tav. 03-07 - 96030079

P.	Codice	Q.	① ②	Denominazione Benennung	③	Description	④	Description
1	03795025	1		FOVVA PUMP		COMP		PUMP
2	03235000	3		VII SOLLAUM		VIS		SOLENS
3	03385000	3		ROSELA SOLLAUM		ROSELE		SOLENS
4	03616900	3		RACCORDO ANSO L'USS		RACCORD		CONNECTION
5	03168400	4		GIAMM / ONI DICI L'UES		GIAMM / ONI		SOLENS
6	13152900	1		RACCORDO ANSO L'USS		RACCORD		CONNECTION
7	03120029	1		UIRO ROLE		UIRO		P-P
8	13152600	1		RACCORDO ANSO L'USS		RACCORD		CONNECTION
9	13153900	3		RACCORDO ANSO L'USS		RACCORD		CONNECTION
10	03168200	3		GIAMM / ONI DICI L'UES		GIAMM / ONI		SOLENS
11	13E43302	1		VA VO A V NII		SOLLAUM		SOLENS
12	13152800	2		RACCORDO ANSO L'USS		RACCORD		CONNECTION
13	03111929	1		UIRO ROLE		UIRO		P-P
14	03111934	1		UIRO ROLE		UIRO		P-P
15	03605900	1		GLAVA KALMWE		GLAVA		SOLENS
16	13790200	1		MOTOR MOTOR		MOTOR		MOTOR
17	03121419	1		UIRO ROLE		UIRO		P-P
18	03611200	1		RACCORDO ANSO L'USS		RACCORD		CONNECTION



- ① MOTORE DIESEL: RADIATORE ACQUA - OLIO
- ② MOTEUR DIESEL: RADIATEUR EAU HUILE
- ③ DIESEL ENGINE: WATER OIL RADIATOR
- ④ DIESEL MOTOR: OIL AND WASSERKUEHLER

TAV. 03-08
96030080

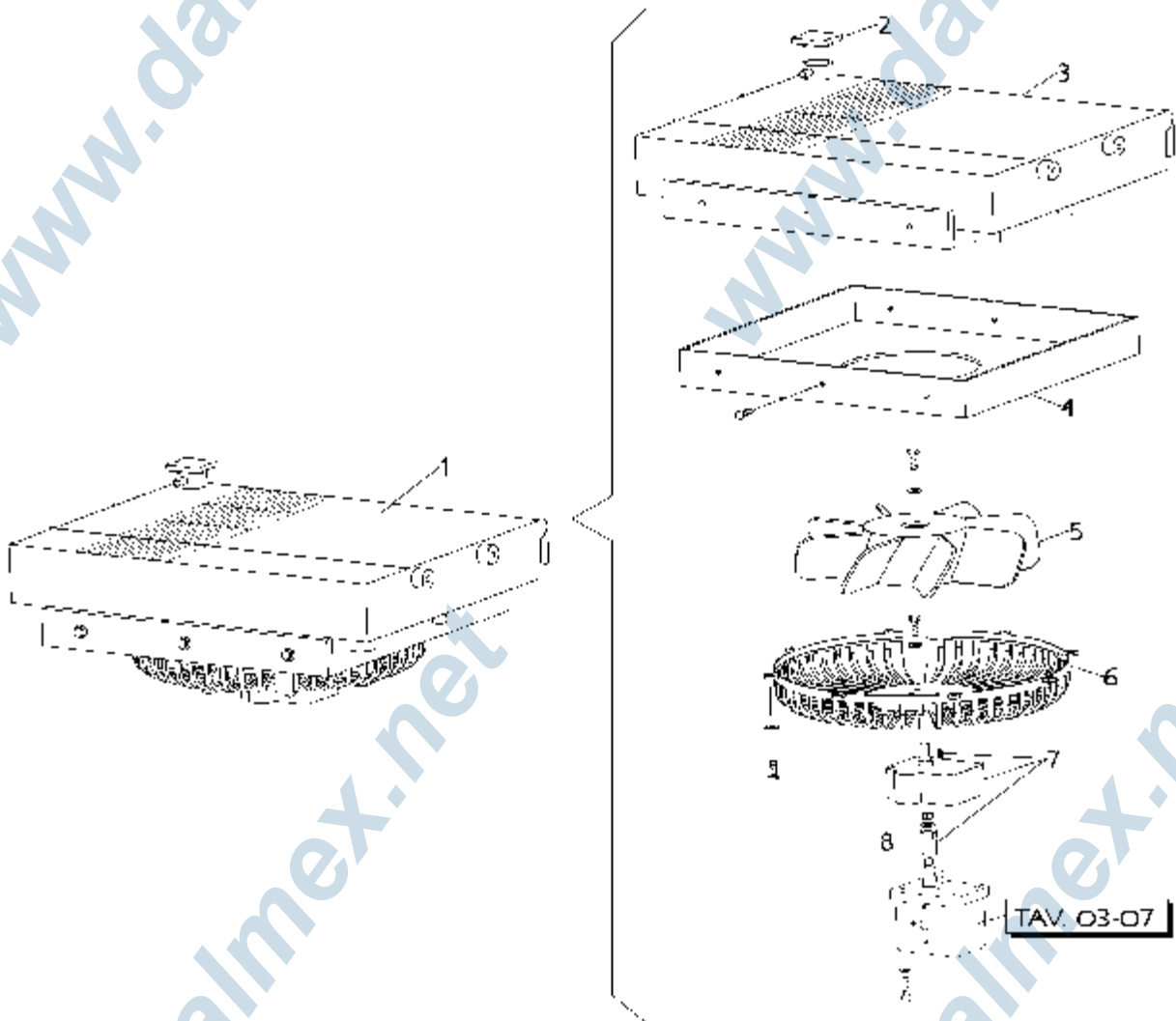

www.dalmex.net

www.dalmex.net



Tav. 03-08 - 96030080

P.	Codice	Q.	① ② Denominazione Benennung	③ Description	④ Description
1	33840514	1	RAIATORI KIL... APP... STOP... CORPORA... KORPER HE ZKORFER	RAI... CORP...	RAI... CORP...
2	64840502	1	CONVOG... KONVOY... VAN... LUI... G... G... G... KI... SA... G... KUPPLING	CONVOY... KONVOY... VAN... LUI... G... G... G... KI... SA... G... KUPPLING	CONVOY... KONVOY... VAN... LUI... G... G... G... KI... SA... G... KUPPLING
3	64840503	1			
4	64840504	1			
5	64840505	1			
6	64840505	1			
7	64840507	1			
8	64840508	1			

- ① DISTRIBUTORE SERVIZI
- ② DISTRIBUTEUR DES SERVICES
- ③ FUNCTIONS DISTRIBUTOR
- ④ VERBRAUCHERNVERTEILER

TAV. 04-01
96040147

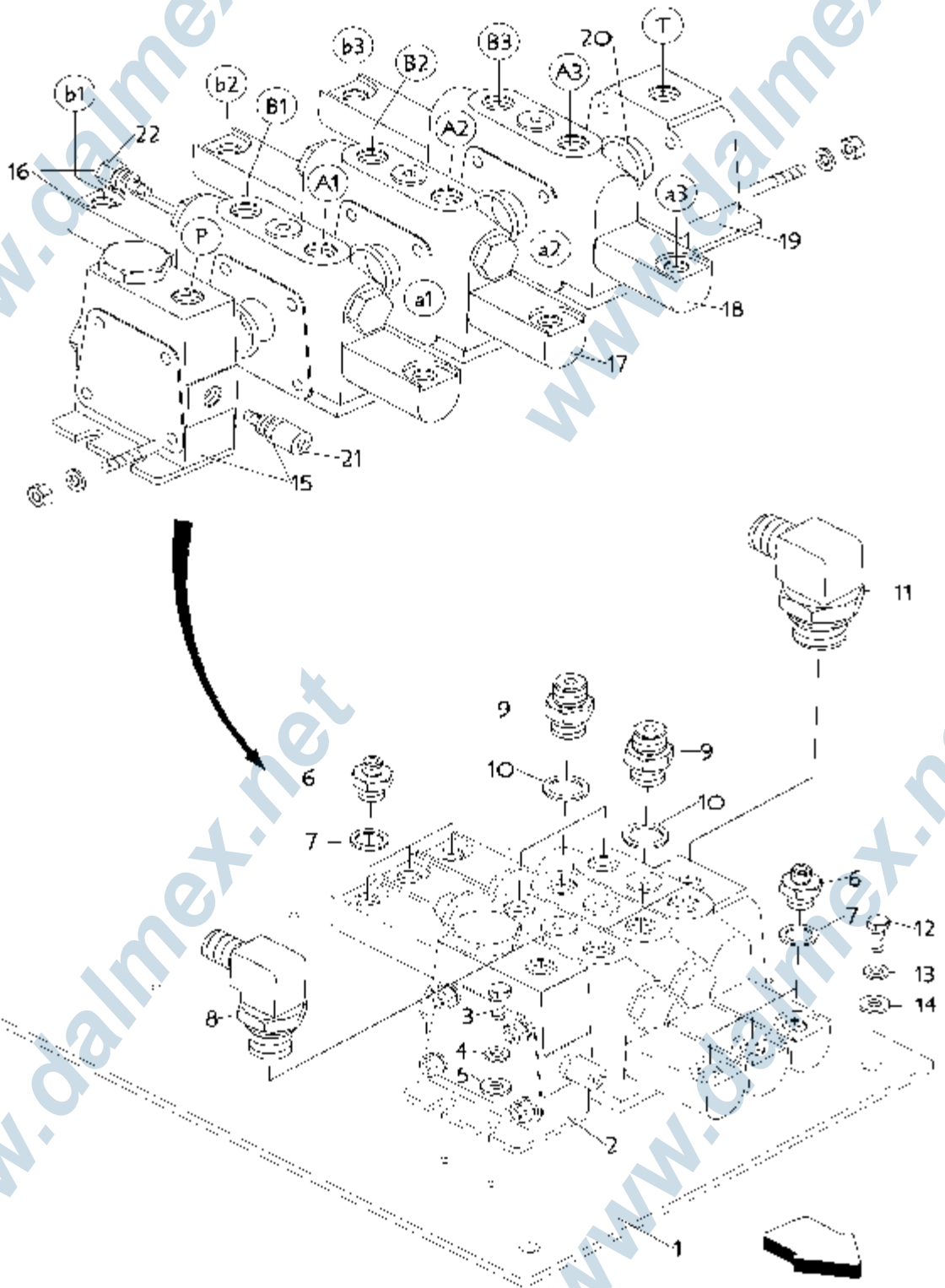



Tav. 04-01 - 96040147

P.	Codice	Q.	Ⓐ Ⓑ Denominazione Benennung	Ⓔ Description	ⒼⒸ Description
1	45152414	1	SUPPORTE LAME RUNG	SUPPORT ?	SUP-PORT
2	13184026	1	DISTRIBUZIONE VALVOLA	DISTRIBUTOR ?	DISTRIBUTOR
3	03220401	4	VITI	WAS	SCREW
4	03383000	4	SCARABO ROSETTA SCHELE	IRON BOLT	WASHER ?
5	03383311	4	ROSETTA SCHELE	IRON BOLT	WASHER ?
6	13150036	5	RACCORDO ANSOLESS	WASHER ?	CONNECTION
7	03168500	6	GIAMBRONE DIELETRICI	WASHER ?	WASHER ?
8	1316*403	1	RACCORDO ANSOLESS	WASHER ?	CONNECTION
9	13152800	5	RACCORDO ANSOLESS	WASHER ?	CONNECTION
10	03168200	6	GIAMBRONE DIELETRICI	WASHER ?	WASHER ?
11	1316*206	1	RACCORDO ANSOLESS	WASHER ?	CONNECTION
12	03230301	4	VITI	WAS	SCREW
13	03385050	4	SCARABO ROSETTA SCHELE	IRON BOLT	WASHER ?
14	03385401	4	ROSETTA SCHELE	IRON BOLT	WASHER ?
15	63186878	1	FRAMMENTO SILIZIO	IRON BOLT	FRAGMENT
16	63186879	1	FRAMMENTO FRAMMENTO	FRAGMENT	FRAGMENT
17	63186880	1	FRAMMENTO FRAMMENTO	FRAGMENT	FRAGMENT
18	63186881	1	FRAMMENTO FRAMMENTO	FRAGMENT	FRAGMENT
19	63186882	1	FRAMMENTO FRAMMENTO	FRAGMENT	FRAGMENT
20	4	ANELLO CORRONE	WASHER ?	WASHER ?	
21	63187634	1	VALVOLA MAX	WASHER ?	WASHER ?
22	63187635	1	VALVOLA MAX	WASHER ?	WASHER ?



- Ⓜ GRUPPO VALVOLE
- Ⓜ GROUP DE VALVES
- Ⓜ VALVES GROUP
- Ⓜ VENTIL GRUPE

TAV. 04-02

96040148

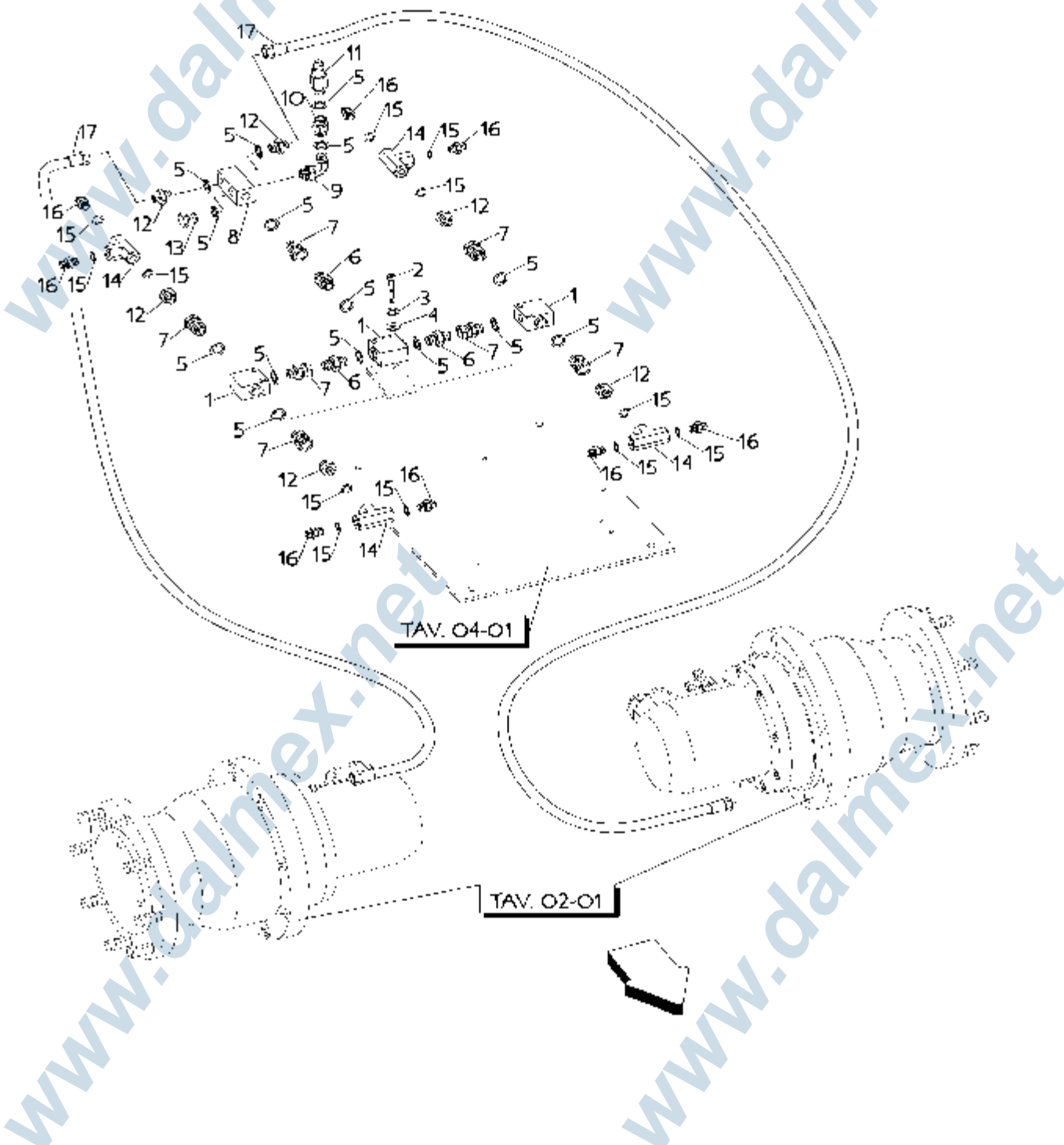



Tav. 04-02 - 96040148

P.	Codice	Q.	Ⓐ Ⓑ	Denominazione Benennung	Ⓕ	Description	ⒼⒸ	Description
1	13842401	3	VA VO A V N III	SOL-PA			VALV	
2	03214600	2	VII SOL-PAUM	VIS			SOL-PA	
3	03383000	2	ROSI TA SOL III	RON D III			WAS I ?	
4	03383311	2	ROSI TA SOL III	RON D III			WAS I ?	
5	03168500	15	GLIMN / ONI DICI LUNE	GA-RI-UR			GA-RI	
6	13152700	3	RACCORDO ANSO I LSS	ANCOO RI			CO-NE-TO-RI	
7	13150032	7	RACCORDO ANSO I LSS	ANCOO RI			CO-NE-TO-RI	
8	03635004	1	RACCORDO ANSO I LSS	ANCOO RI			CO-NE-TO-RI	
9	13161201	1	RACCORDO ANSO I LSS	ANCOO RI			CO-NE-TO-RI	
10	03620201	1	FRO-LINGA V-RI-AN-RI-LUNE	ANCOO RI			CO-NE-TO-RI	
11	03841606	1	FR-SRO-SI-O D-SUG-VA-O I ?	FR-SRO-SI-AI			FR-SI-O	
12	13150036	8	RACCORDO ANSO I LSS	ANCOO RI			CO-NE-TO-RI	
13	13166010	1	A-RO SIO-EN	RO-TO-RI			RI-TO	
14	03639830	4	GLIMN / ONI V-RI-AN-RI-LUNE	ANS-M-RI-VE			LI-NO-RI	
15	03160012	12	GLIMN / ONI DICI LUNE	GA-RI-UR			GA-RI	
16	13150402	8	RACCORDO ANSO I LSS	ANCOO RI			CO-NE-TO-RI	
17	03121425	2	URO RO-RI	UR-RI			UR-RI	

- Ⓡ GRUPPO ELETTROVALVOLE
- Ⓡ GROUPE DE VALVES ELECTRIQUES
- Ⓡ ELECTROVALVES GROUP
- Ⓡ ELECTROVENTIL GRUPPE

TAV. 04-03
96040192

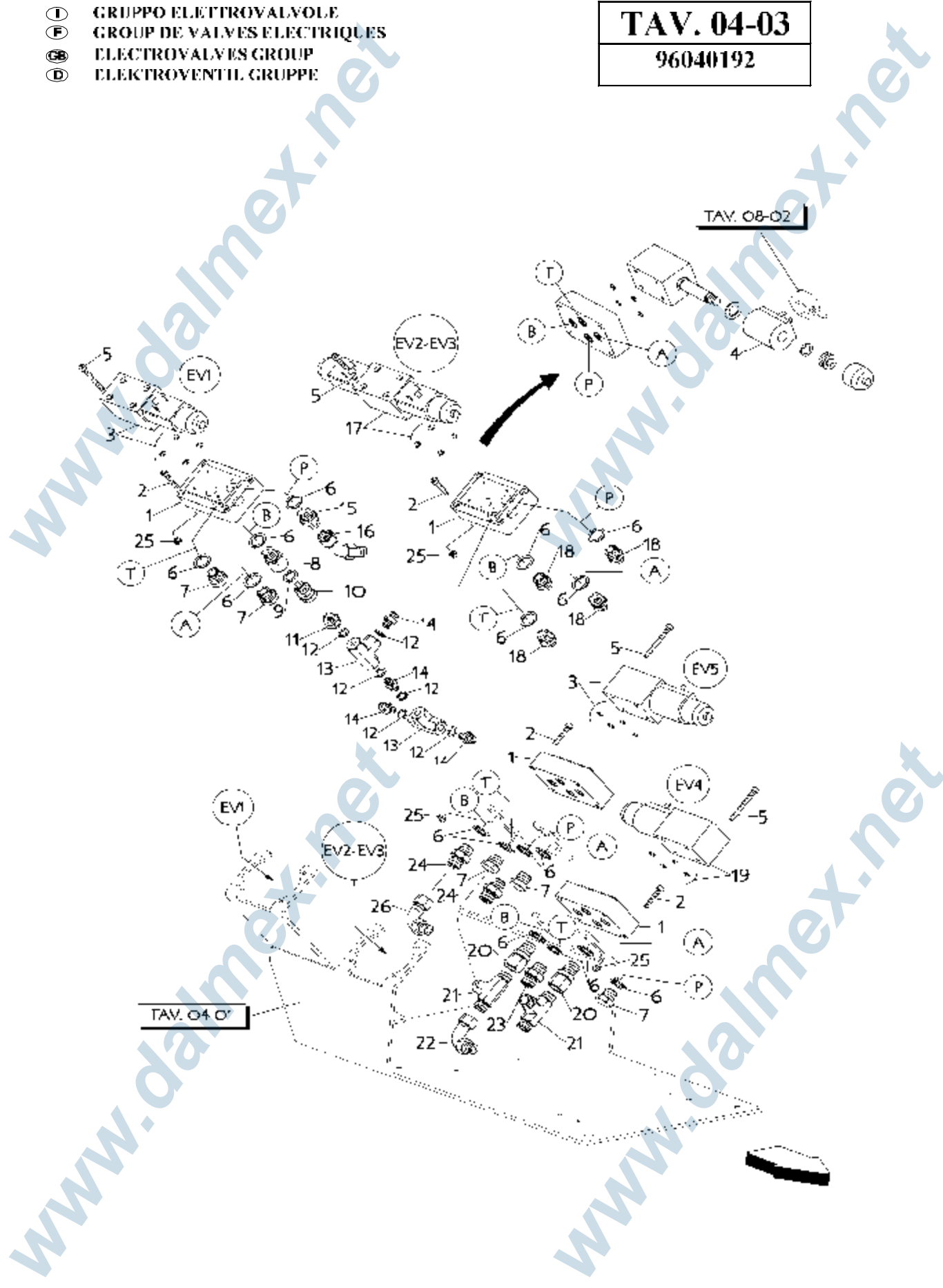

TAV. 04 03

Tav. 04-03 - 96040192

P.	Codice	Q.	① ② Denominazione Benennung	③ Description	④ Description
1	33181001	4	FASIERA FLAT	PACQUI	PAC
2	03214903	16	VII SOI NAU II	VIS	SOI NAU
3	33180008	2	FLAT ROVINATA FLAT ROVINATI	SOUPAFI FLAT QU	FLAT ROVINATA
4	64180101	5	SOI NAU II SOI NAU II	SOI NAU II	SOI NAU II
5	03214601	16	VII SOI NAU II	VIS	SOI NAU
6	03168200	16	GIUMEN / ONI DICI LUBES	GIUMEN LUB	GIUMEN LUB
7	13160013	5	STOPI STOPI	FIGURA	FIGURA
8	13154300	1	RACCORDO ANSO LUBS	RACCORDO	CONNEZIONE
9	03168500	1	GIUMEN / ONI DICI LUBES	GIUMEN LUB	GIUMEN LUB
10	13150032	1	RACCORDO ANSO LUBS	RACCORDO	CONNEZIONE
11	13150036	1	RACCORDO ANSO LUBS	RACCORDO	CONNEZIONE
12	03160012	6	GIUMEN / ONI DICI LUBES	GIUMEN LUB	GIUMEN LUB
13	03639830	2	GIUNZIONE VIBRANTE	ANS MUBES	GIUNZIONE
14	13150402	4	RACCORDO ANSO LUBS	RACCORDO	CONNEZIONE
15	13153950	1	RACCORDO ANSO LUBS	RACCORDO	CONNEZIONE
16	03600006	1	CLAVA KUMVIR	CLAVA	CLAVA
17	33180020	1	FLAT ROVINATA FLAT ROVINATI	SOUPAFI FLAT QU	FLAT ROVINATA
18	13150045	4	RACCORDO ANSO LUBS	RACCORDO	CONNEZIONE
19	33180017	1	FLAT ROVINATA FLAT ROVINATI	SOUPAFI FLAT QU	FLAT ROVINATA
20	13150000	2	RACCORDO ANSO LUBS	RACCORDO	CONNEZIONE
21	03630001	2	GIUNZIONE VIBRANTE	ANS MUBES	GIUNZIONE
22	03605900	1	CLAVA KUMVIR	CLAVA	CLAVA
23	25200522	1	RACCORDO ANSO LUBS	RACCORDO	CONNEZIONE
24	13152800	2	RACCORDO ANSO LUBS	RACCORDO	CONNEZIONE
25	03363100	16	DAI MUBES	DAI	DAI
26	03600007	1	CLAVA KUMVIR	CLAVA	CLAVA

- ① IMPIANTO OLEODINAMICO SOLLEVAMENTO
- ② INSTALLATION HYDRAULIQUE DE SOULEVEMENT
- ③ LIFTING HYDRAULIC SYSTEM
- ④ HYDRAULISCHE ANLAGE FÜR HEBUNG

TAV. 04-04
96040193

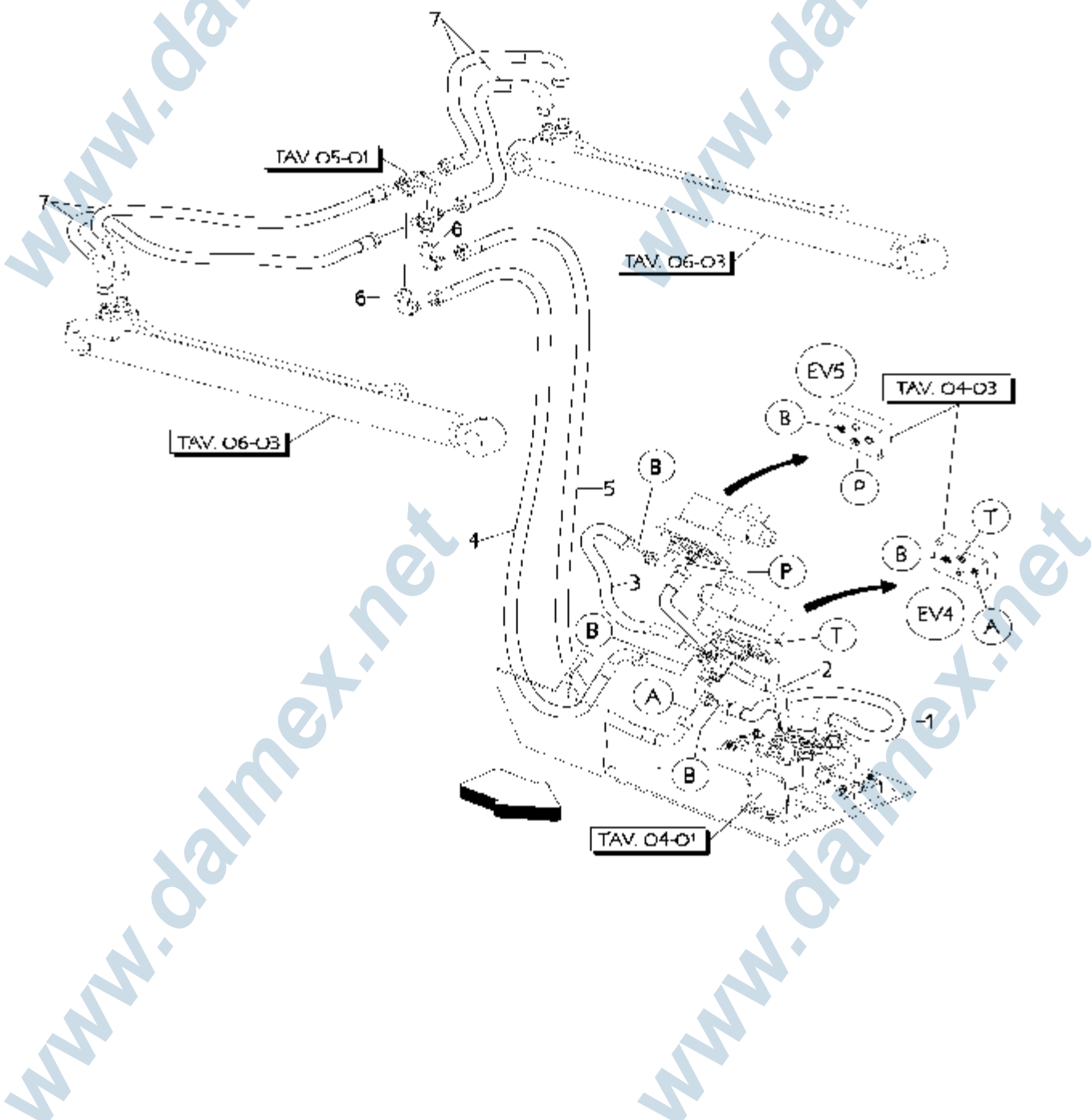



Tav. 04-04 - 96040193

P.	Codice	Q.	① ②	Denominazione Benennung	③	Description	④	Description
1	03111833	1	U10 P011 3		JVAL		F-PI	
2	03111810	1	U10 P011 3		JVAL		F-PI	
3	03111941	1	U10 P011 3		JVAL		F-PI	
4	03111931	1	U10 P011 3		JVAL		F-PI	
5	03111940	1	U10 P011 3		JVAL		F-PI	
6	03605900	2	CL. 5VA K 3 L M W 1 R		EXE. 10 3		F-3We	
7	03111929	4	U10 P011 3		JVAL		F-PI	



- ① IMPIANTO OLEODINAMICO BENNA
- ② INSTALLATION OLEODYNAMIQUE BENNE
- ③ SKIP OLEODYNAMIC SYSTEM
- ④ OLEODYNAMISCHE ANLAGE SCHAUFEL

TAV. 04-05
96040201

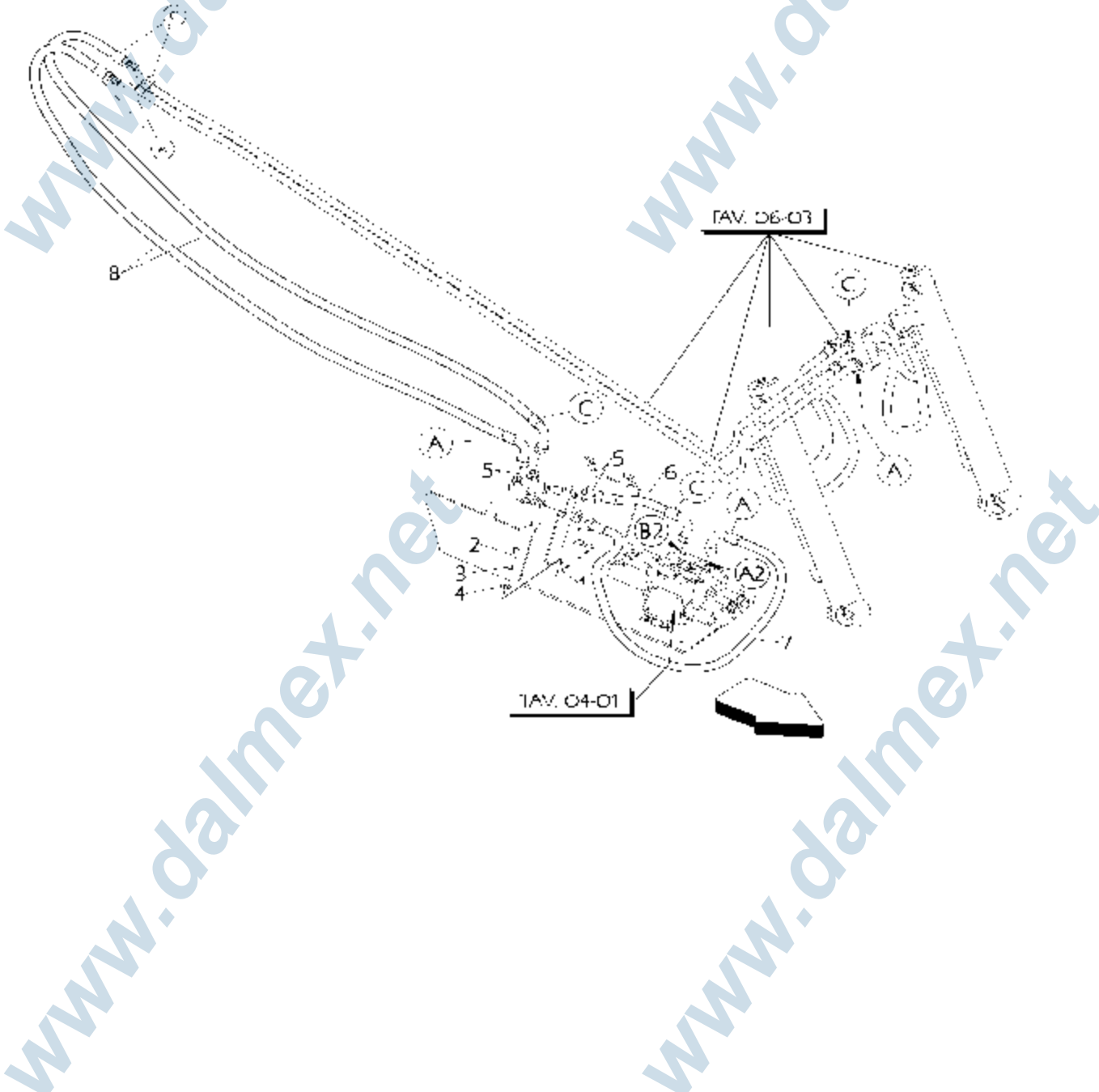



Tav. 04-05 - 96040201

P.	Codice	Q.	① ② Denominazione Benennung	③ Description	④ Description
1	45152535	1	SUPPORTO LAMELLUNG	SUPPORTO	SUP-032
2	03220401	2	VITI SERRAVALLE	VITI	SERRAVALLE
3	03383000	2	ROSELE SERRAVALLE	ROSELE	WASHER
4	03383311	2	ROSELE SERRAVALLE	ROSELE	WASHER
5	13165008	2	RACCORDO ANSICLUS	RACCORDO	CONNESSIONE
6	03111932	1	ORO RODRI	JYAL	F-PI
7	03111870	1	ORO RODRI	JYAL	F-PI
8	03116820	2	ORO RODRI	JYAL	F-PI



- ① IMPIANTO OLEODINAMICO PRESA DI FORZA
- ② INSTALLATION OLEODYNAMIQUE PRISE DE FORCE
- ③ OLEODYNAMIC SYSTEM POWER TAKE-OFF
- ④ OLEODYNAMISCHE ANLAGE FÜR NEBENANTRIEB

TAV. 04-06
96040152

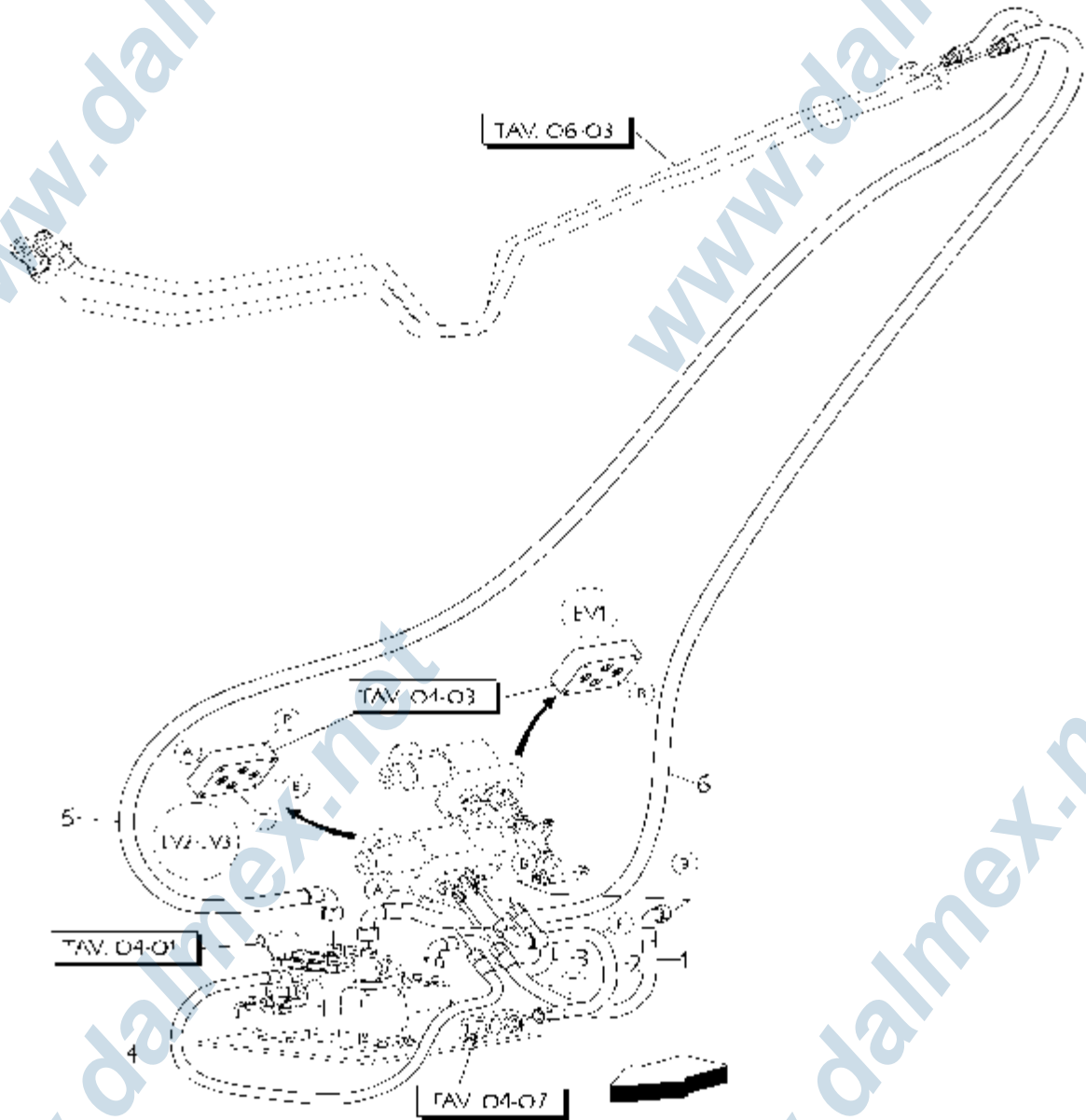



Tav. 04-06 - 96040152

P.	Codice	Q.	① ②	Denominazione Benennung	③	Description	④	Description
1	03121893	1	UIC PC11.8		JVAL		F-PI	
2	03121897	1	UIC PC11.8		JVAL		F-PI	
3	03121870	1	UIC PC11.8		JVAL		F-PI	
4	03121866	1	UIC PC11.8		JVAL		F-PI	
5	03116822	1	UIC PC11.8		JVAL		F-PI	
6	03116821	1	UIC PC11.8		JVAL		F-PI	

- Ⓢ IMP. OLEODIN. ASPIRAZIONE - MANDATA - SCARICO
- Ⓣ INSTALL. OLEODYN. D'ASPIRATION - ENVOI - SORTIE
- Ⓝ SUCTION - DELIVERY - RECOVERY HYDRAULIC SYSTEM
- Ⓞ SAUG - FÖRDERUNG - AUSLASS HYDRAULIKANLAGE

TAV. 04-07
96040194

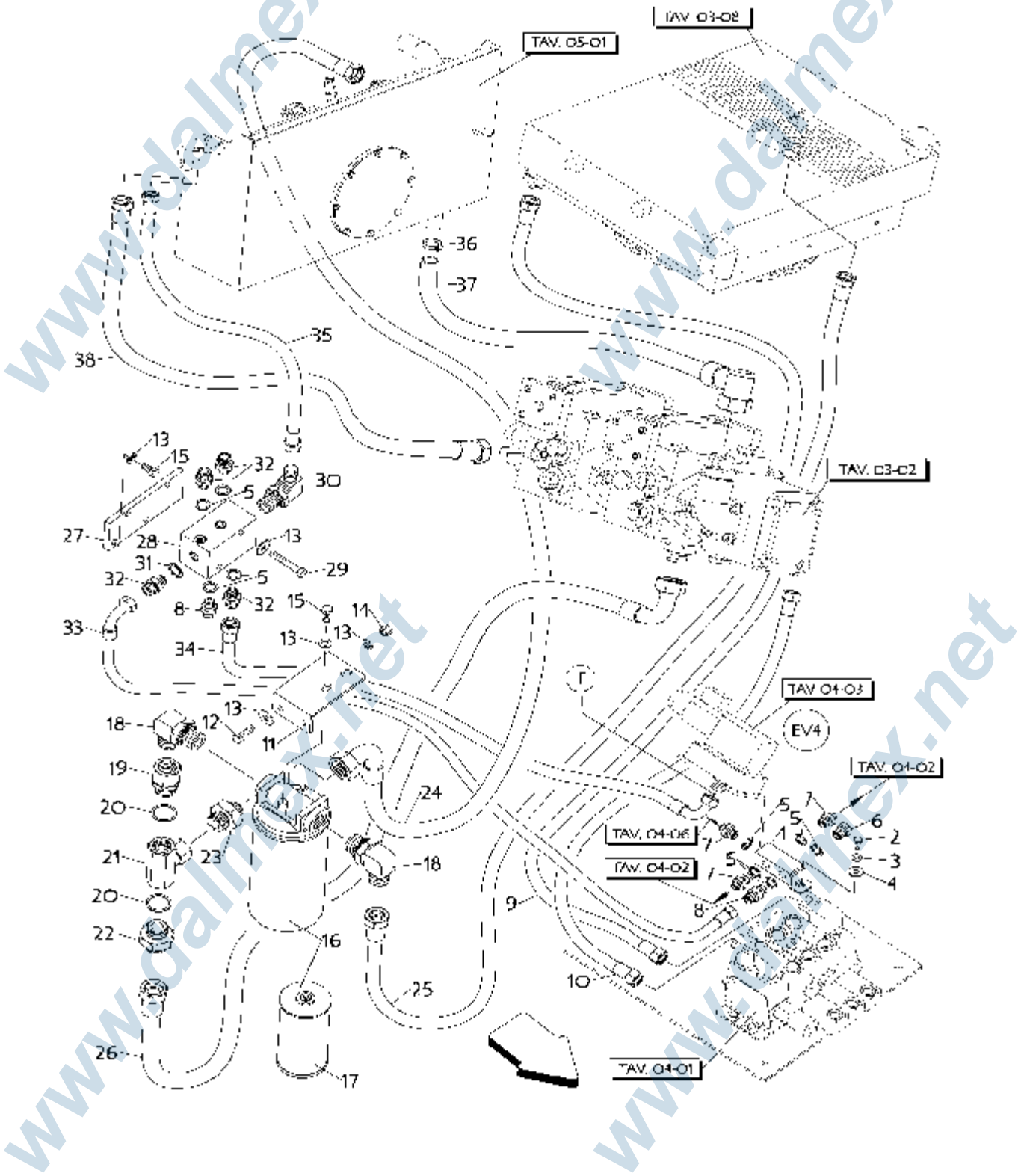

Tav. 04-07 - 96040194

P.	Codice	Q.	① ②	Denominazione Benennung	④	Description	⑥	Description
1	25200650	1		RACCORDO ANSO I UNO	ANSO 010		CONNECTOR	
2	03220401	1		VITI SOLIDAUM	VIT		SCREW	
3	03383000	1		ROSETTA SCHIETTA	RONDETTI		WASHER	
4	03383201	1		ROSETTA SCHIETTA	RONDETTI		WASHER	
5	03168500	9		GIUNTA / ONI DIECI UNO	GIUNTA		CLAMP	
6	13166010	1		AVVIO SICUREZZA	BUCCIA		PLUG	
7	13150036	3		RACCORDO ANSO I UNO	ANSO 010		CONNECTOR	
8	13152700	2		RACCORDO ANSO I UNO	ANSO 010		CONNECTOR	
9	03130016	1		ORLO ROTTA	JYAL		F-PI	
10	03111879	1		ORLO ROTTA	JYAL		F-PI	
11	45152406	1		SUPPORTO LAMELLINO	SUPPORTO		SHIMMER	
12	03230601	2		VITI SOLIDAUM	VIT		SCREW	
13	03385050	10		ROSETTA SCHIETTA	RONDETTI		WASHER	
14	03365100	2		DAVVO MUTTER	CIRCU		NUT	
15	03230501	4		VITI SOLIDAUM	VIT		SCREW	
16	03844805	1		FILTRO FILTRO	FR		FILT	
17	62845010	1		CARTELLINA FILTRO INSIEME	CARTELLINA		CARTRIDGE	
18	13161205	2		RACCORDO ANSO I UNO	ANSO 010		CONNECTOR	
19	13150001	1		RACCORDO ANSO I UNO	ANSO 010		CONNECTOR	
20	03168000	2		GIUNTA / ONI DIECI UNO	GIUNTA		CLAMP	
21	03630007	1		GIUNTA VITIBUNG	ANSO I UNO		BUNG	
22	13153000	1		RACCORDO ANSO I UNO	ANSO 010		CONNECTOR	
23	13154000	1		RACCORDO ANSO I UNO	ANSO 010		CONNECTOR	
24	03121804	1		ORLO ROTTA	JYAL		F-PI	
25	03131010	1		ORLO ROTTA	JYAL		F-PI	
26	03130021	1		ORLO ROTTA	JYAL		F-PI	
27	45152275	1		SUPPORTO LAMELLINO	SUPPORTO		SHIMMER	
28	03635001	1		RACCORDO SCARICO ANSO I UNO	RACCORDO		DISCHARGE CONNECTOR	
29	03231000	2		VITI SOLIDAUM	VIT		SCREW	
30	13161403	1		RACCORDO ANSO I UNO	ANSO 010		CONNECTOR	
31	03168200	1		GIUNTA / ONI DIECI UNO	GIUNTA		CLAMP	
32	13153950	4		RACCORDO ANSO I UNO	ANSO 010		CONNECTOR	



Tav. 04-07 - 96040194

P.	Codice	Q.	① ②	Denominazione Benennung	③	Description	④	Description
33	03120035	1	① ②	UIRO ROU 3		JYAL		F-PI
34	03121801	1	① ②	UIRO ROU 3		JYAL		F-PI
35	03121422	1	① ②	UIRO ROU 3		JYAL		F-PI
36	13577300	1		FASCIA SCHELE		WAD		C AWP
37	03130602	1	① ②	UIRO ROU 3		JYAL		F-PI
38	03131403	1	① ②	UIRO ROU 3		JYAL		F-PI



www.dalmex.net

www.dalmex.net

www.dalmex.net

www.dalmex.net



- ① IMPIANTO OLEODINAMICO TRASMISSIONE IDROSTATICA
- ② INSTALL. OLEODYN. TRANSMISSION HYDROSTATIQUE
- ③ HYDROSTATIC TRANSMISSION OLEODYNAMIC SYSTEM
- ④ OLEODYNAMISC. ANLAGE HYDROSTATISCHES BETRIEBS

TAV. 04-08

96040154

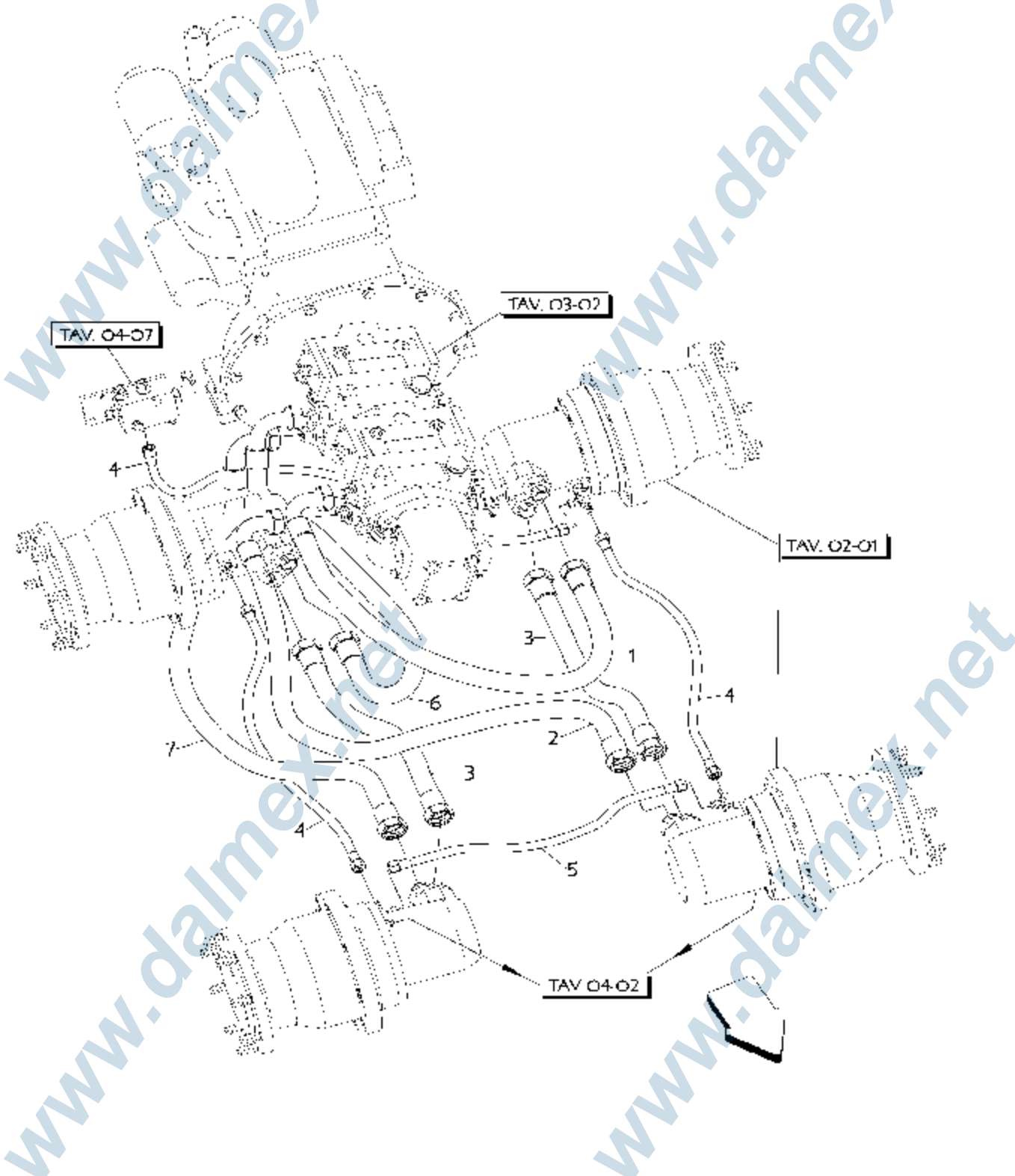



Tav. 04-08 - 96040154

P.	Codice	Q.	① ②	Denominazione Benennung	③	Description	④	Description
1	03111945	1	UIK PC11.3		JVAL		F-PI	
2	03111944	1	UIK PC11.3		JVAL		F-PI	
3	03111449	2	UIK PC11.3		JVAL		F-PI	
4	03121424	3	UIK PC11.3		JVAL		F-PI	
5	03121427	5	UIK PC11.3		JVAL		F-PI	
6	03111943	6	UIK PC11.3		JVAL		F-PI	
7	03111938	7	UIK PC11.3		JVAL		F-PI	



- ① IMPIANTO OLEODINAMICO MANIPOLATORE DESTRO
- ② INSTALL. OLEODYNAMIQUE MANIPULATEUR DROIT
- ③ RIGHT MANIPULATOR OLEODYNAMIC SYSTEM
- ④ RECHTS STEUERHEBEL OLEODYNAMISCHE ANLAGE

TAV. 04-09
96040155

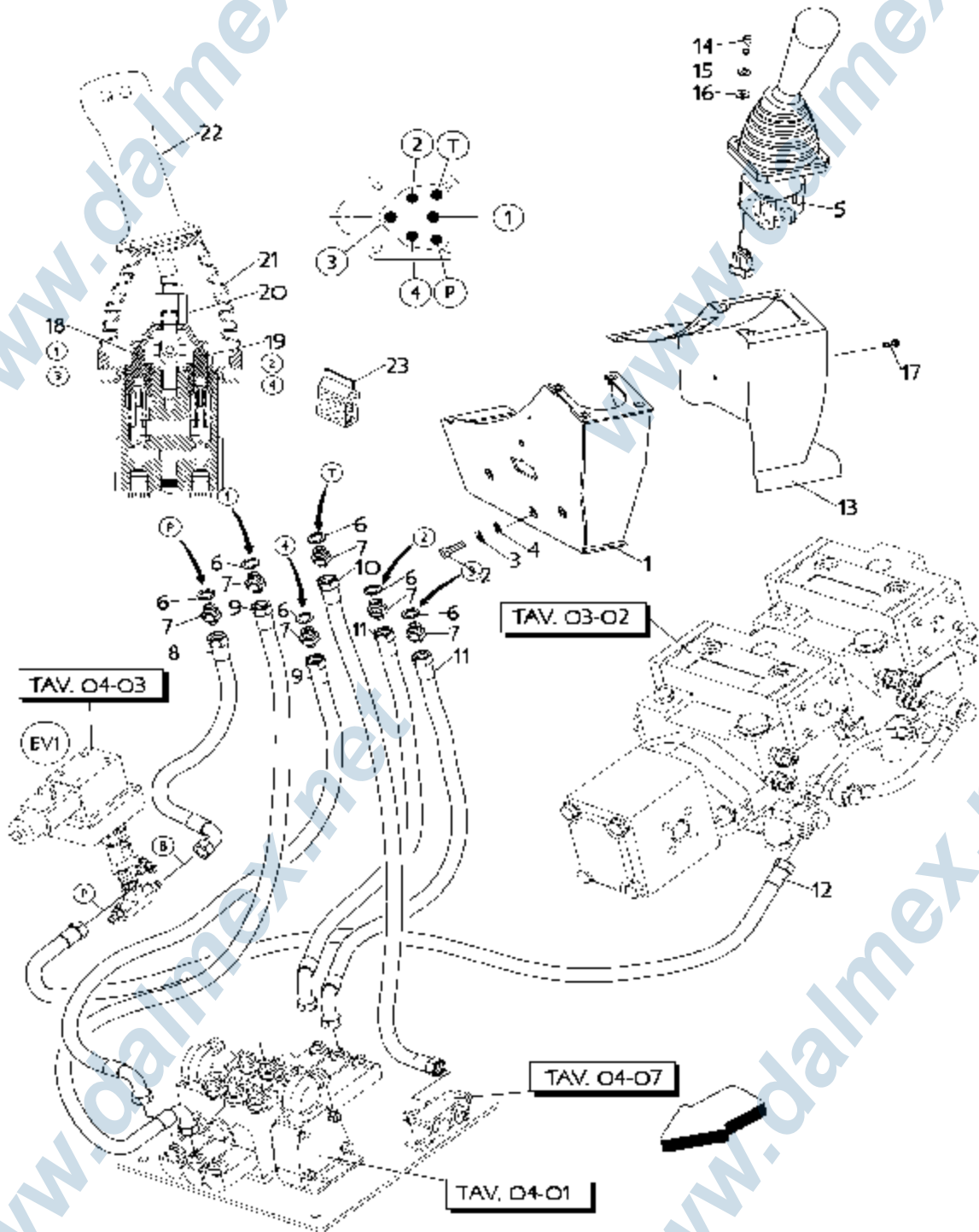

www.dalmex.net



Tav. 04-09 - 96040155

P.	Codice	Q.	Ⓐ Ⓑ	Denominazione Benennung	Ⓕ	Description	ⒼⒸ	Description
1	99040051	1		SUPPORTO LAMELLINE		SUPPORT		SUP-032
2	03230601	3		VITI SICUREZZA		WAS		SECURE
3	03385000	3		ROSETTA SICUREZZA		RONDELLI		WASHER
4	03385201	3		ROSETTA SICUREZZA		RONDELLI		WASHER
5	13184318	1		MANIFESTAZIONE SILURANTE		MANIFESTOR		MANIFESTOR
6	03168500	6		GRANIZIONE DIECI LITRI		GRANIZOR		GRANIZOR
7	13150036	3		PRODOTTO ANSICUREZZA		PRODOTTI		CONNECTION
8	03121869	1		UNITO ROTTORI		JYAL		F-PI
9	03121890	2		UNITO ROTTORI		JYAL		F-PI
10	03121425	1		UNITO ROTTORI		JYAL		F-PI
11	03121864	2		UNITO ROTTORI		JYAL		F-PI
12	03121423	1		UNITO ROTTORI		JYAL		F-PI
13	99040049	1		CANTIER KASIMIR		CANTIER		CANTIER
14	03225000	4		VITI SICUREZZA		WAS		SECURE
15	03383000	4		ROSETTA SICUREZZA		RONDELLI		WASHER
16	03383311	4		ROSETTA SICUREZZA		RONDELLI		WASHER
17	03227700	1		VITI SICUREZZA		WAS		SECURE
18	63188422	2		KUJAWA SA / KL 2VI		KUJAWA		KUJAWA
19	63188440	2		KUJAWA SA / KL 2VI		KUJAWA		KUJAWA
20	63188439	1		KUJAWA SA / S ANCI		KUJAWA		KUJAWA
21	63188427	1		COMANDO SILURANTE		COMANDO		CONTROL DEVICE
22	63187003	1		KUJAWA SA / GRI		KUJAWA		KUJAWA
23	62497810	1		KUJAWA SA / DIECI LITRI		KUJAWA		KUJAWA



- Ⓡ IMPIANTO OLEODINAMICO MANIPOLATORE SINISTRO
- Ⓡ INSTALL. OLEODYNAMIQUE MANIPLATEUR GAUCHE
- Ⓡ LEFT MANIPULATOR OLEODYNAMIC SYSTEM
- Ⓡ LINKS STEUERHEBEL OLEODYNAMISCHE ANLAGE

TAV. 04-10
96040156

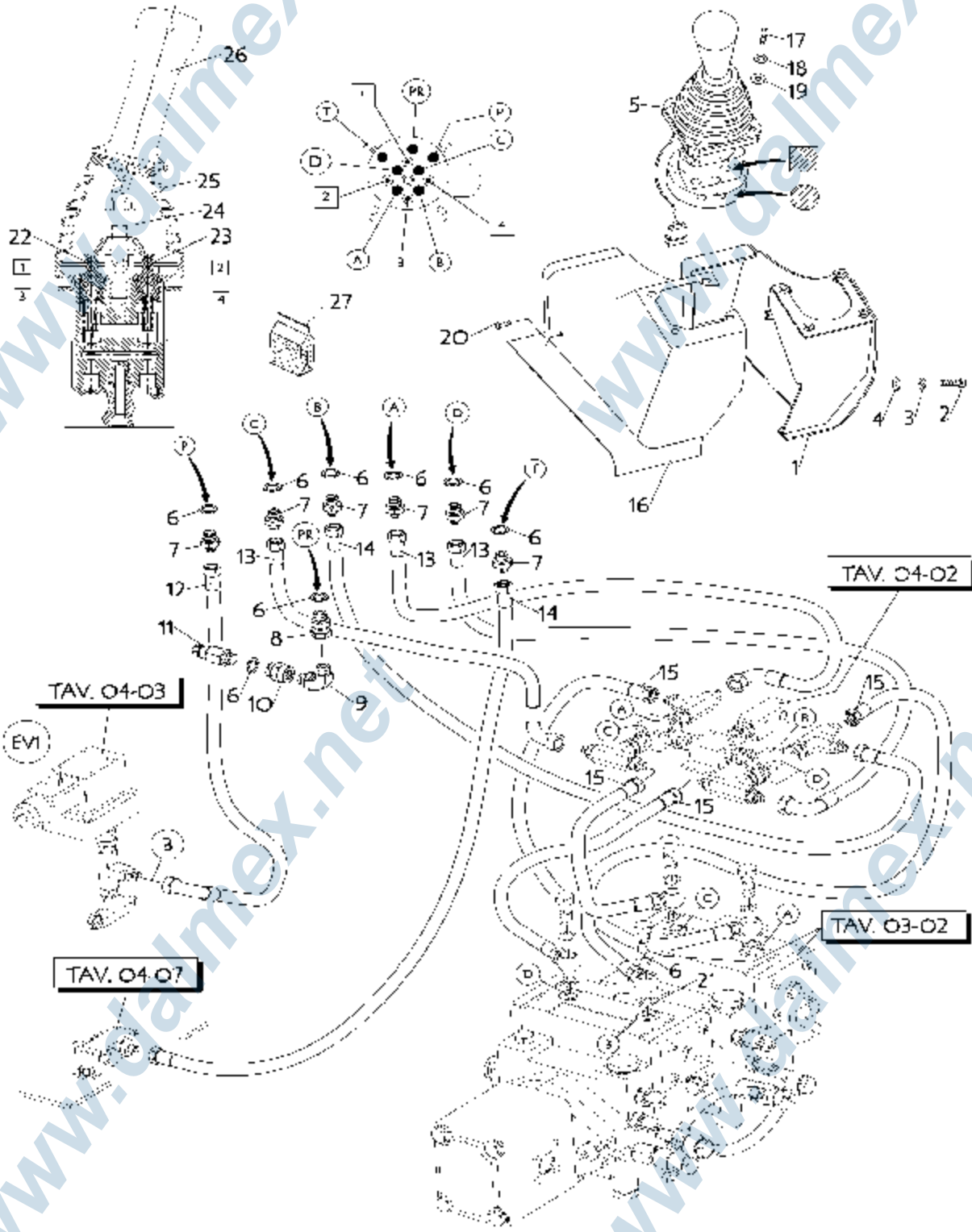

Tav. 04-10 - 96040156

P.	Codice	Q.	① ②	Denominazione Benennung	③	Description	④	Description
1	99040056	1		SUPPORTO LAMELLUNG		SUPPORT		SUPPORT
2	03230601	3		VIT SOLLAU 31		VIT		SEAL W
3	03385000	3		ROSETTA SCHLEIF		IRON BUSH		WASHER
4	03385201	3		ROSETTA SCHLEIF		IRON BUSH		WASHER
5	13184317	1		MANIFESTAZIONE STRUTTURALE		MANIFEST JIR		MANIFESTATION
6	03168500	12		GIAMBRIZIONE DIECI LUBRI		GASKET JIR		GASKET
7	13150036	3		RACCORDO ANSIC LUS		WASHER		CONNECTION
8	13150032	1		RACCORDO ANSIC LUS		WASHER		CONNECTION
9	13161201	1		RACCORDO ANSIC LUS		WASHER		CONNECTION
10	03620201	1		FRELLINGA V. 21 ANGI LUNG		WASHER		CONNECTION
11	03841606	1		FRASCHIATO DUCAWAL 2		FRASCHES AT		SPWICH
12	03121862	1		URO ROTTI		JYAL		F-P
13	03121863	3		URO ROTTI		JYAL		F-P
14	03121426	2		URO ROTTI		JYAL		F-P
15	03122031	4		URO ROTTI		JYAL		F-P
16	99040050	1		CANILE KASIM		CAN 2		CRANKCASE
17	03225000	4		VIT SOLLAU 31		VIT		SEAL W
18	03383000	4		ROSETTA SCHLEIF		IRON BUSH		WASHER
19	03383311	4		ROSETTA SCHLEIF		IRON BUSH		WASHER
20	03227700	1		VIT SOLLAU 31		VIT		SEAL W
21	03168510	4		GIAMBRIZIONE DIECI LUBRI		GASKET JIR		GASKET
22	63188437	2		K. CULWA SA / KL 21		KIT MANIFOLD		KIT FITTING
23	63188438	2		K. CULWA SA / KL 21		KIT MANIFOLD		KIT FITTING
24	63188439	1		K. ASIA SA / SANCE		KIT DIE		KIT ROD
25	63188427	1		K. CULWA SA / KOPLICE 21 R		KIT GASKET		KIT PROTECTION
26	63187002	1		K. MFLUGN 21 R SA / GRT		KIT FORK		KIT MANIFOLD
27	62497816	1		K. GJARNIMON SA / DIECI LUBRI		KIT JOINTS		KIT SEALS

- ① SERBATOIO OLIO
- ② RESERVOIR HUILE
- ③ OILTANK
- ④ OILTANK

TAV. 05-01
96050130

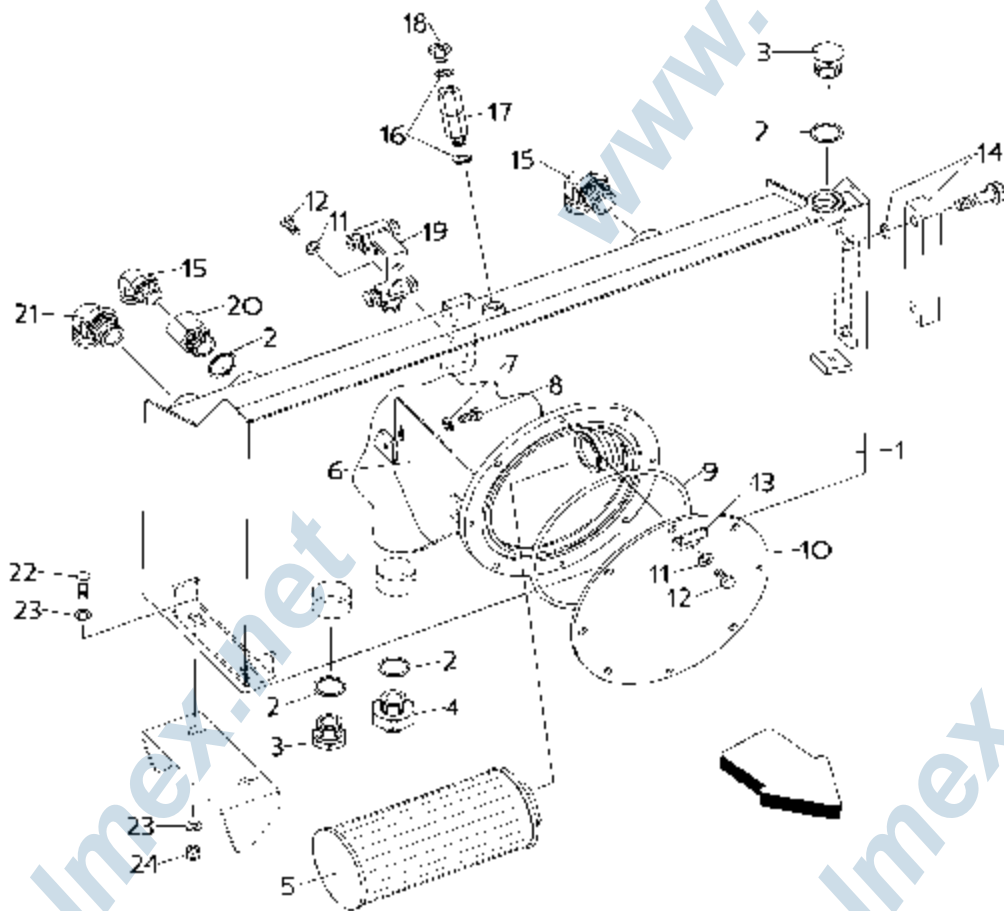

Tav. 05-01 - 96050130

P.	Codice	Q.	① ② Denominazione Benennung	③ Description	④ Description
1	15100675	1	8. NITRICO ANK	NISS 200 2	TANK
2	15100688	1	FAVOLA SCHIETI	GIOSION	BUKILTAG
3	03383311	2	ROSETTA SCHIETI	FRONTELLI	WASHER
4	03220401	2	VAL SCHIETI	VIS	SCREW
5	03840406	1	FILTRO FILTR	FR	FILTR
6	03491002	1	ANELLO ORO OR RING	ANK AUO 2	OR RING
7	15100414	1	COMPRESSO D ORO	COMPRIO	COMP RING
8	03385050	10	ROSETTA SCHIETI	FRONTELLI	WASHER
9	03230301	10	VAL SCHIETI	VIS	SCREW
10	03842204	1	VALVOLA CO STAND	VALV 170LIT	OIL MEASURINGSTICK
11	03168400	1	GIUNTA / ONI DIECI LUBRI	GIUNTA JIR	GASKET
12	13161204	2	RACCORDO ANSO LUBRI	RACCORD	CONNECTION
13	03168500	2	GIUNTA / ONI DIECI LUBRI	GIUNTA JIR	GASKET
14	13843501	1	VALVOLA V NUB	SCULPAP	VALV
15	03842500	1	APPENDIBILE FENDIOLUNGHESSTOPPLEN	FRUGEL OR SCULPAP	FR A LITE PLUG
16	25200483	1	GIUNTA VIBRIZIONE	ANS M 3 1/2	LUBRICK
17	03168000	4	GIUNTA / ONI DIECI LUBRI	GIUNTA JIR	GASKET
18	13154610	1	RACCORDO ANSO LUBRI	RACCORD	CONNECTION
19	13161205	1	RACCORDO ANSO LUBRI	RACCORD	CONNECTION
20	13154000	1	RACCORDO ANSO LUBRI	RACCORD	CONNECTION
21	13160039	2	APP STOP PIN	FRUGEL OR	PLUG
22	03230601	4	VAL SCHIETI	VIS	SCREW
23	03385401	3	ROSETTA SCHIETI	FRONTELLI	WASHER
24	03365100	4	VALV MULTI	ORCO	NUT
25	45152539	1	SUPPORTO LUBRIZIONE	SUPPORT	SUPPORT

- ① BRACCI
- ② BRAS
- ③ ARMS
- ④ ARMEN

TAV. 06-01
96060131

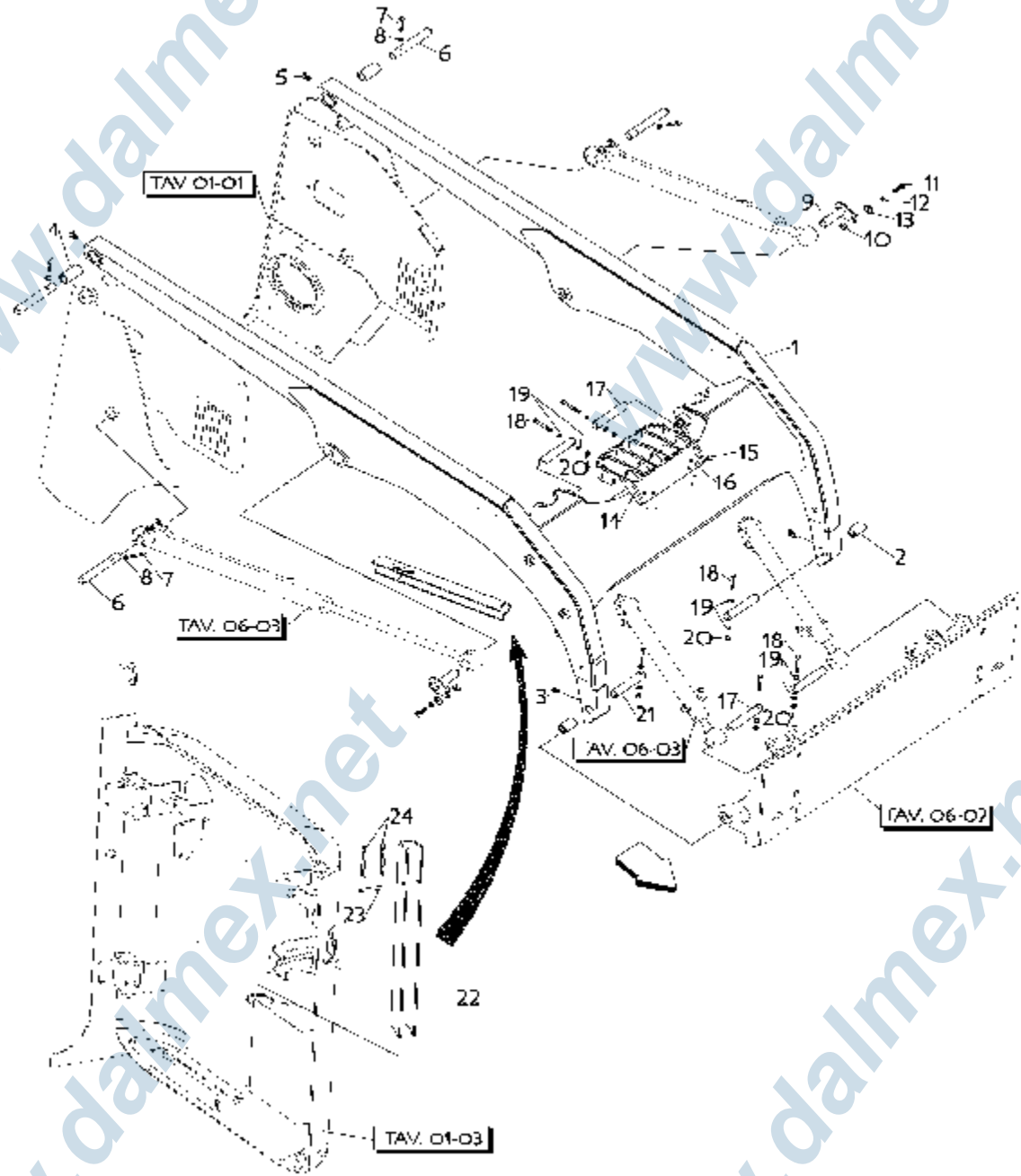



Tav. 06-01 - 96060131

P.	Codice	Q.	① ②	Denominazione Benennung	④	Description	⑥	Description
1	55080734	1	①	TIPO	④	CLASSI	⑥	TEAM
2	33590628	2	②	ROCCIA BUCHI	④	COLITE	⑥	LUSE
3	03511200	2	②	INTEGRATORE SCHEMIB?	④	GRASSI	⑥	LUBRICA
4	33590634	2	②	ROCCIA BUCHI	④	COLITE	⑥	LUSE
5	03510700	2	②	INTEGRATORE SCHEMIB?	④	GRASSI	⑥	LUBRICA
6	45C71026	4	②	PISTO DIZI	④	PVO	⑥	FIN
7	03231200	4	②	VIT SCHEMIB	④	VIS	⑥	SCHEM
8	03385000	4	②	ROSTIA SCHEMIB	④	RONDITI	⑥	WASIT
9	45C71027	2	②	PISTO DIZI	④	PVO	⑥	FIN
10	45C70800	2	②	DISTRIBUI DISTRIBUI/STOCK	④	ENTRACISI	⑥	SPACI
11	03240301	2	②	VIT SCHEMIB	④	VIS	⑥	SCHEM
12	03386000	2	②	ROSTIA SCHEMIB	④	RONDITI	⑥	WASIT
13	03386011	2	②	ROSTIA SCHEMIB	④	RONDITI	⑥	WASIT
14	30060429	1	②	SCAMIN STU	④	GRADIN	⑥	SI
15	03230701	4	②	VIT SCHEMIB	④	VIS	⑥	SCHEM
16	03385050	4	②	ROSTIA SCHEMIB	④	RONDITI	⑥	WASIT
17	45C71029	4	②	PISTO DIZI	④	PVO	⑥	FIN
18	03231400	6	②	VIT SCHEMIB	④	VIS	⑥	SCHEM
19	03385201	12	②	ROSTIA SCHEMIB	④	RONDITI	⑥	WASIT
20	03365100	6	②	DA MUTTI	④	GRADU	⑥	NUT
21	45C71030	2	②	PISTO DIZI	④	PVO	⑥	FIN
22	23050075	1	②	ASTA STANGI	④	LOGI	⑥	REG
23	45071034	1	②	PISTO DIZI	④	PVO	⑥	FIN
24	03739810	2	②	GRUPPI SPIN	④	GRUPPI	⑥	SPIN



- ① ATTACCO BENNA
- ② ATTELAGE POUR BENNE
- ③ BUCKET ATTACHMENT
- ④ SCHALFELANSCHLUSS

TAV. 06-02
96060121

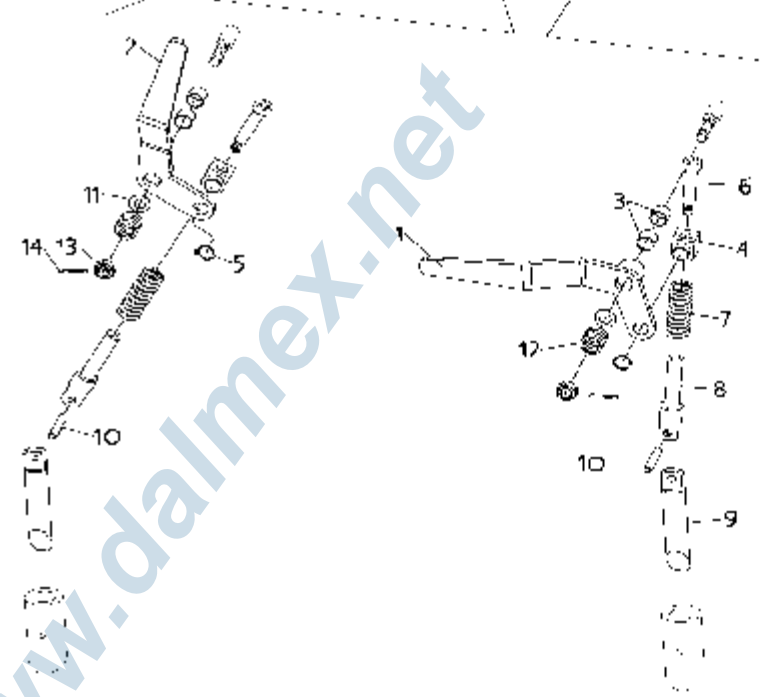
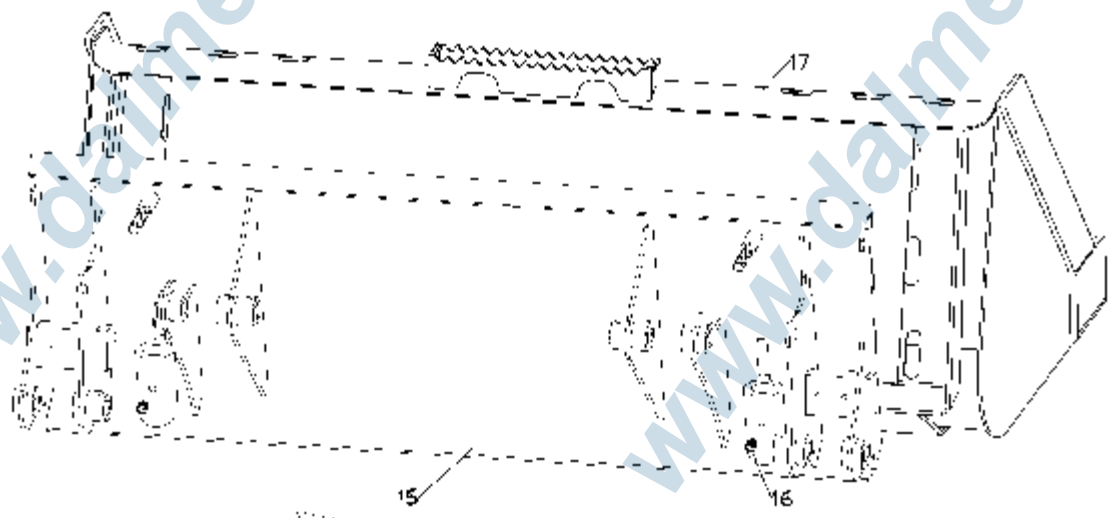



Tav. 06-02 - 96060121

P.	Codice	Q.	Ⓐ Ⓑ	Denominazione Benennung	Ⓕ	Description	ⒼⒸ	Description
1	23150189	1		ELVA ELBET		ELVER		ELVER
2	23150185	1		ELVA ELBET		ELVER		ELVER
3	33593610	4		BROCCIA BROCCIA		COLLET		COLLET
4	47200002	2		ALICOD KUPPLING		ALICOD		COUPLER
5	03429400	2		ANILLO ZARINCO SPLITTING		ANILLO ZARINCO		SPLITTING
6	03259950	2		VIT SCARUMI		VIT		SCREW
7	03730209	2		MOLA ELBET		BRISSET		SPRING
8	47200001	2		EDSILLA GARNI		COLLETT		LOCK
9	45071032	2		PIRNO BOLINA		PINO		PIN
10	03408800	2		SPINA SI		GROUP		PIN
11	03388201	2		ROSETTA SCILLA		RONDELLI		WASHER
12	03730210	2		MOLA ELBET		BRISSET		SPRING
13	03368020	2		DAVO MUTTER		ORCIO		NUT
14	03432900	2		GRUPPA SPINA		GROUP		SPIN PIN
15	55090073	1		ALICOD KUPPLING		ALICOD		COUPLER
16	03511200	2		INTEGRATORE SCARUMI		GRASSIURE		LUBRICATOR
17	10011919	1		BRINA GRUPPA		BRIN		SKIP



- Ⓢ IMPIANTO OLEODINAMICO BENNA - BRACCI
- Ⓣ INSTALLATION OLEODYNAMIQUE BRAS - GODET
- Ⓚ ARMS - BUCKET HYDRAULIC SYSTEM
- Ⓝ ARMEN - SCHAUFEL OELDYNAMISCHES ANLAGE

TAV. 06-03

96060132

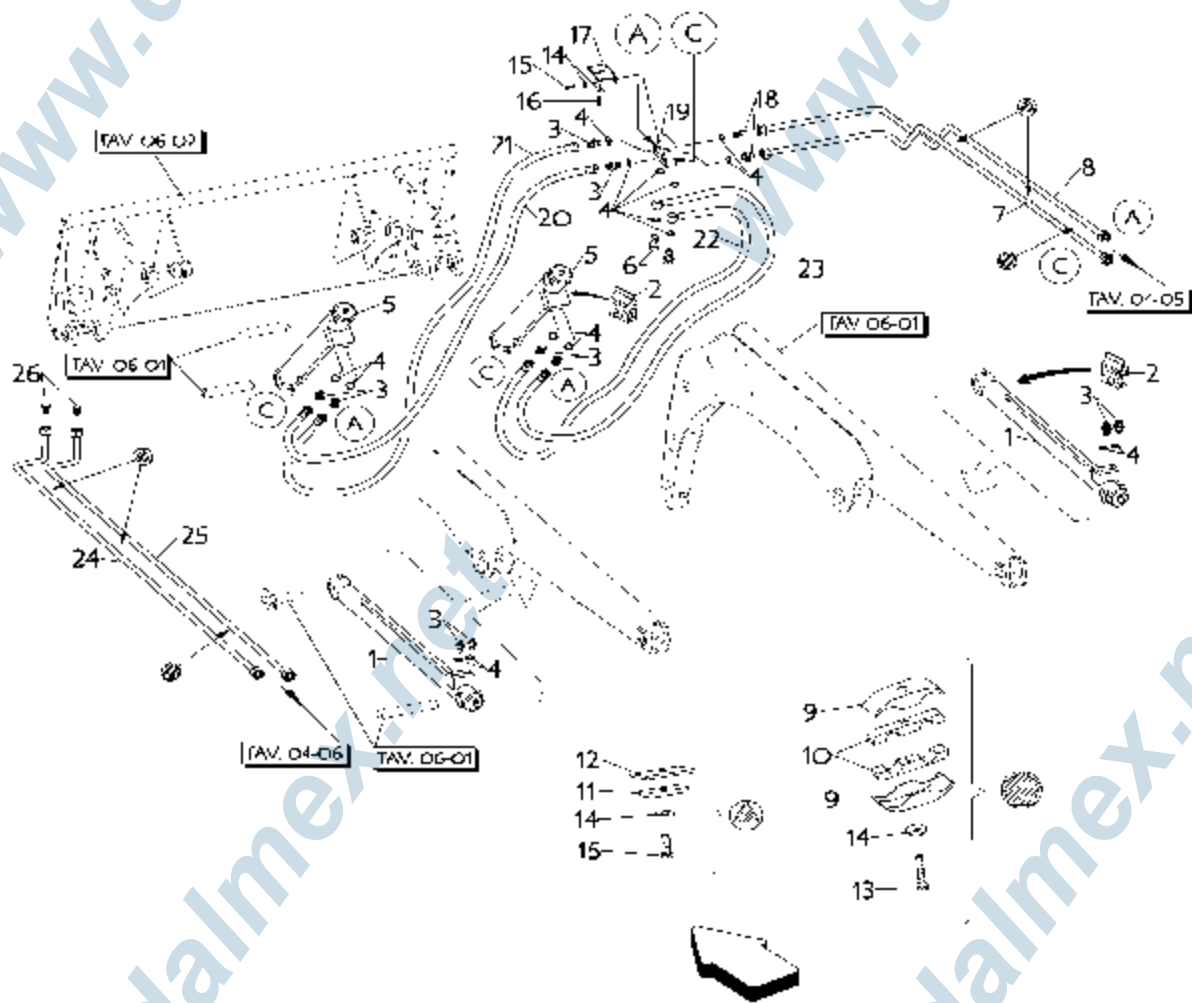

Tav. 06-03 - 96060132

P.	Codice	Q.	Ⓐ Ⓑ Denominazione Benennung	Ⓔ Description	Ⓖ Description
1	03180049	2	GI IN JED ZY INB R	GY INDR	GY INDR
2	72498076	4	K GJARMIMEN SA Z DIO LUGAS	KH JONIS	KH JONIS
3	13152800	10	RACCORDO ANSO LUS	RACCORD	CONNECTION
4	03168200	16	GEJEN / ONI DIO LUGAS	GEJEN	GEJEN
5	03180053	2	GI IN JED ZY INB R	GY INDR	GY INDR
6	03150600	2	VII SOL RAUM	VIS	SOIL W
7	25160381	1	UIRO ROH R	JYAL	F-P
8	25160382	1	UIRO ROH R	JYAL	F-P
9	13572419	4	FASIRINO FLATI	FACJIL	F-A
10	13572420	2	COHAR BUNDRING	COHAR	COHAR
11	45500222	4	STAN S TRASHUG	STRAN	STRAN
12	45500223	4	FROH ZICNI SCHILZ	FRO LITION	FRO LITION
13	03220901	2	VII SOL RAUM	VIS	SOIL W
14	03383201	9	ROSI TA SCHILZ	RON TILL	ROSI T
15	03220601	6	VII SOL RAUM	VIS	SOIL W
16	03220701	1	VII SOL RAUM	VIS	SOIL W
17	45152556	1	SUPPORICO LAL T RUNG	SUPPOR	SUPPOR
18	13160048	2	RACCORDO ANSO LUS	RACCORD	CONNECTION
19	25200659	1	RACCORDO ANSO LUS	RACCORD	CONNECTION
20	03111432	1	UIRO ROH R	JYAL	F-P
21	03111455	1	UIRO ROH R	JYAL	F-P
22	03112024	1	UIRO ROH R	JYAL	F-P
23	03112025	1	UIRO ROH R	JYAL	F-P
24	25160384	1	UIRO ROH R	JYAL	F-P
25	25160383	1	UIRO ROH R	JYAL	F-P
26	13162604	2	W-RO STOPLIN	WROCK ON	W-RO



- Ⓜ CABINA
- Ⓧ CABINE
- Ⓞ CAB
- Ⓝ KABINE

TAV. 07-01
96070107

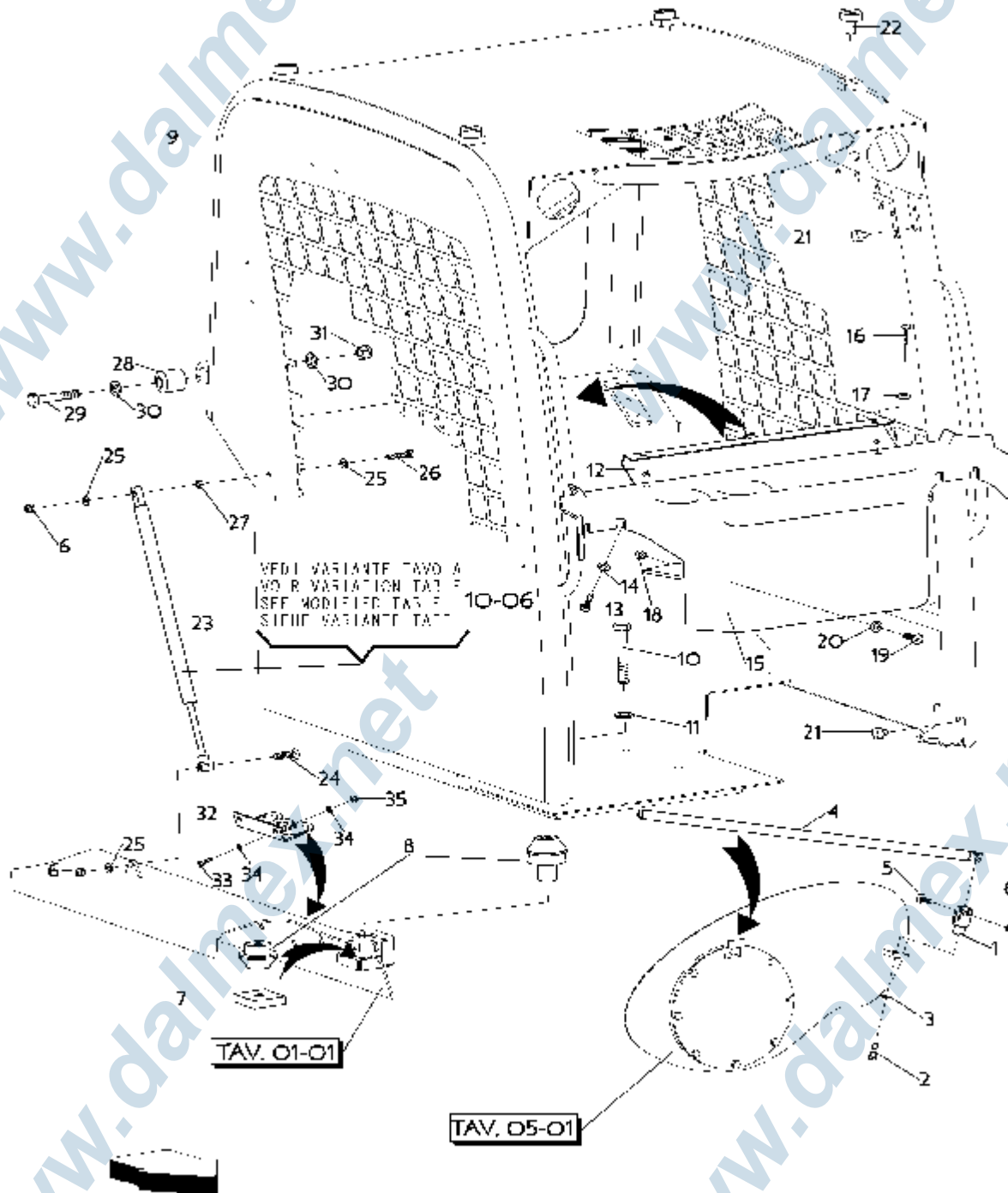

Tav. 07-01 - 96070107

P.	Codice	Q.	Ⓐ Ⓑ Denominazione Benennung	Ⓔ Description	Ⓖ Description
1	13430002	1	FORCETTA GAS	COLICHI	LOCK
2	03230301	1	VITI SCELTAUINI	VIS	SCREW
3	03385050	1	ROSELE SCELTAUINI	IRONBIT	WASHER
4	30150457	1	ASTA SLANGI	LEGI	LEGO
5	03236000	1	VITI SCELTAUINI	VIS	SCREW
6	03365100	5	FRANCO MUTTER	CIRCO	NUT
7	55C12122	2	FRANCO KUPPLING	AL. AG.	COMBINATION
8	03520903	2	ANTIVIBRANTE DAMPING	ANTIVIBRANTE	VIBRATION DAMPING
9	30150410	1	GALINIA KAVIN	GALINI	COIL
10	03271401	2	VITI SCELTAUINI	VIS	SCREW
11	91870064	2	ROSELE SCELTAUINI	IRONBIT	WASHER
12	30150542	1	FRANCO KUPPLING	AL. AG.	COMBINATION
13	03220610	2	VITI SCELTAUINI	VIS	SCREW
14	03383311	2	ROSELE SCELTAUINI	IRONBIT	WASHER
15	13647222	1	FORNACE CUMULATORE	FORNACE	COMBINATION
16	03227520	2	VITI SCELTAUINI	VIS	SCREW
17	03383350	2	ROSELE SCELTAUINI	IRONBIT	WASHER
18	45C20122	2	DISKANTAL DISKANTALSTUCK	UNIT TO SH	SPACER
19	03207550	2	VITI SCELTAUINI	VIS	SCREW
20	03380700	2	ROSELE SCELTAUINI	IRONBIT	WASHER
21	13480805	10	FRANCO STOPIA	FRANCO	FRIG
22	13480820	4	FRANCO STOPIA	FRANCO	FRIG
23	23210033	2	METALLO GASIFICAZIONE	RESISTENZA GAS	GAS SPRING
24	03237500	2	VITI SCELTAUINI	VIS	SCREW
25	03385201	6	ROSELE SCELTAUINI	IRONBIT	WASHER
26	03231000	2	VITI SCELTAUINI	VIS	SCREW
27	03365001	2	FRANCO MUTTER	CIRCO	NUT
28	03520904	2	ROCCIA BULCISI	COLLE	GLUE
29	03261300	2	VITI SCELTAUINI	VIS	SCREW
30	03388300	4	ROSELE SCELTAUINI	IRONBIT	WASHER
31	03368200	2	FRANCO MUTTER	CIRCO	NUT
32	45152529	1	SUPPORTE FRANCO	SUPPORTE	SUPPORT



Tav. 07-01 - 96070107

P.	Codice	Q.	① ② Denominazione Benennung	③ Description	④ Description
33	03220601	2	VII ROSI 200 M	VII	ROSI 200 M
34	03383201	4	ROSI 1A ROSI 1B	ROSI 111	ROSI 1
35	03364010	2	ROSI MUTTER	ROSI	ROSI



www.dalmex.net

www.dalmex.net

www.dalmex.net

www.dalmex.net





- ① CABINA: PANNELLI - VETRI
- ② CABINE: PANNEAU - VERRE
- ③ CABINE: PANELS - GLASSES
- ④ KABINE: TAFEL - SCHEIBE

TAV. 07-02
96070113

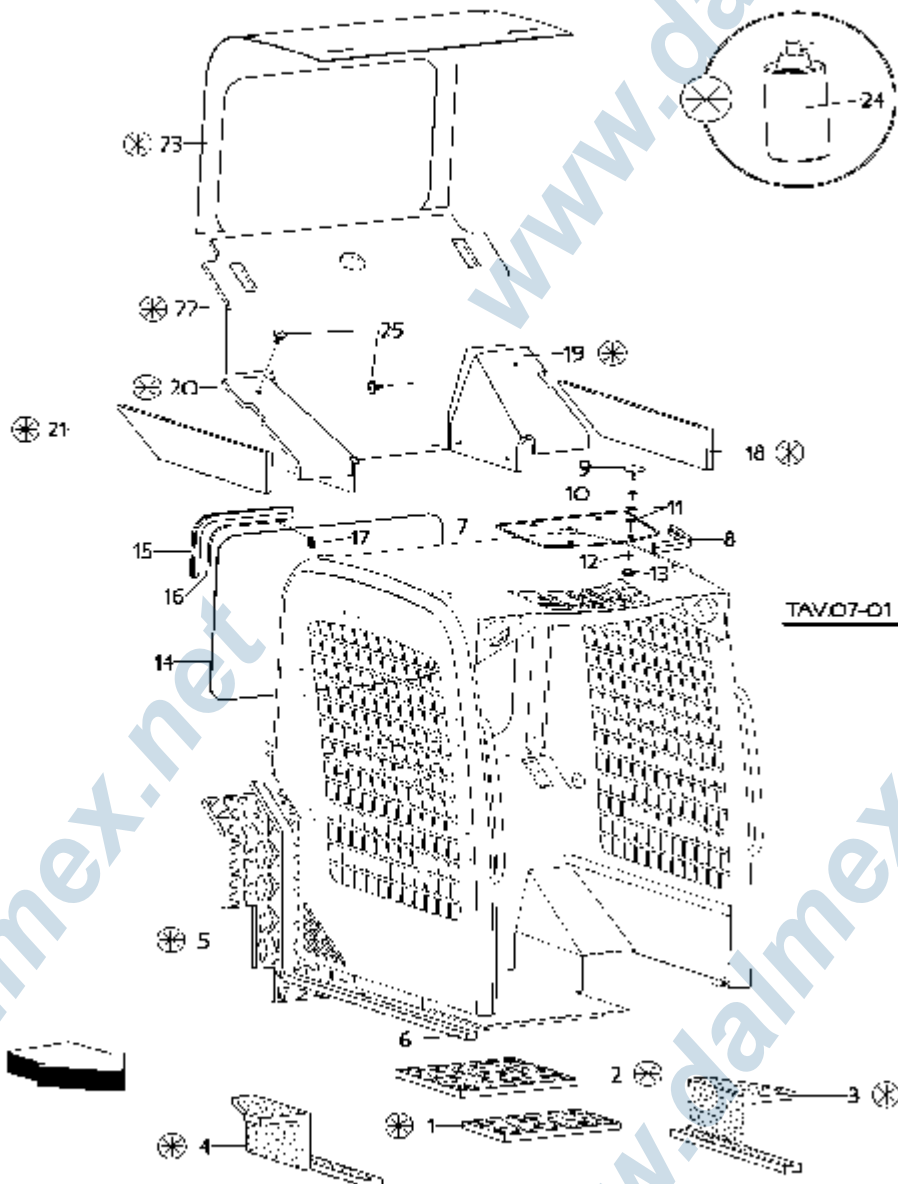

www.dalmex.net

Tav. 07-02 - 96070113

P.	Codice	Q.	Ⓐ Ⓑ Denominazione Benennung	Ⓕ Description	Ⓖ Description
1	30322089	1	FANNI C BEL MESSERIM	PANK AD	PAN
2	30322070	1	FANNI C BEL MESSERIM	PANK AD	PAN
3	30322081	1	FANNI C BEL MESSERIM	PANK AD	PAN
4	30322080	1	FANNI C BEL MESSERIM	PANK AD	PAN
5	30322071	1	FANNI C BEL MESSERIM	PANK AD	PAN
6	30320137	1	GEJEN / ONE DICI UNO	GAKE UR	GAKE I
7	13640017	1	VITRO SCILIB	VITR	GLASS
8	30320135	1	GEJEN / ONE DICI UNO	GAKE UR	GAKE I
9	03579904	4	TERMA VITRO SCILIB NIMMILTRUNG	3 COGSE VITR	GLASSITERMUR
10	03490402	4	ANILICOR OR RINGE	ANK ADOR	OR RING
11	03385701	3	ROSI TA SCILIB	RONI LI	WASLE
12	03385050	4	ROSI TA SCILIB	RONI LI	WASLE
13	03580350	4	POV ILO KNIHLEGERI	POVNI AU	PAN DE KNIB
14	13640014	1	VITRO SCILIB	VITR	GLASS
15	30320117	1	GEJEN / ONE DICI UNO	GAKE UR	GAKE I
16	30320118	1	ANIMA SPANNER	ANISE UR	COBI
17	03731001	1	ANILIC RINGE	ANK AD	RING
18	30322093	1	FANNI C BEL MESSERIM	PANK AD	PAN
19	30322091	1	FANNI C BEL MESSERIM	PANK AD	PAN
20	30322090	1	FANNI C BEL MESSERIM	PANK AD	PAN
21	30322092	1	FANNI C BEL MESSERIM	PANK AD	PAN
22	30322094	1	FANNI C BEL MESSERIM	PANK AD	PAN
23	30322095	1	FANNI C BEL MESSERIM	PANK AD	PAN
24	03709010	1	SOJLANI (QUANTITA S DONO SIC MA) KILIB (RINGE IL NACILICAR)	ADI SII (QUANT SILONIXG NO :	ADI SII (QUANTIT ACCORDING CON CLASSI)
25	13575300	3	ROJ ON KNOPI	ROJ ON	BU LON



- ① CABINA: BARRA DI SICUREZZA – SEDILE
- Ⓕ CABINE: BARRE DE SECURITE – SIEGE
- ⒼⒸ CAB: SECURITY BAR – SEAT
- Ⓓ KABINE: SICHERHEITSSTANGE – SITZPLATZ

TAV. 07-03
96070090

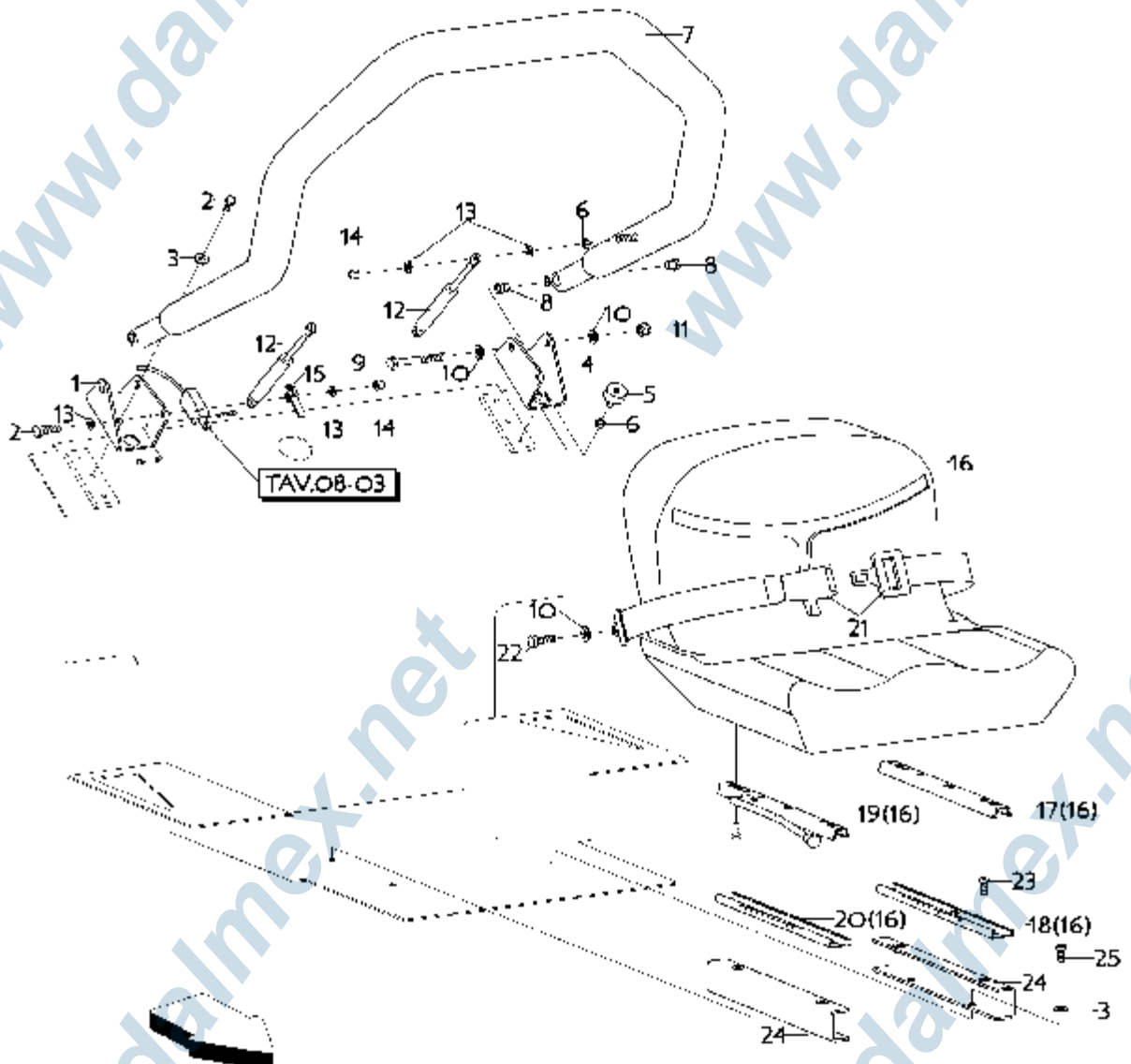



Tav. 07-03 - 96070090

P.	Codice	Q.	Ⓐ Ⓑ	Denominazione Benennung	Ⓔ	Description	Ⓔ	Description
1	23050085	1		SUPPORTO LAMELLUNG		SUPPORT?		SUPP-CR?
2	03230501	6		VITI SOLLAUINI		VIT		SCRE WS
3	03385050	3		ROSETTA SCHELE		RONDELLI		WASHER?
4	23050084	1		SUPPORTO LAMELLUNG		SUPPORT?		SUPP-CR?
5	03520306	2		ANILINAZIONE DAMPING		ANTIVIBAZIONE		VIBRATION DAMPING
6	03365001	4		DAVOLI MUTTER		CIRCU		NUT
7	23050078	1		BARBA SERRAZZA SICILIA SERRANO		BARBIDE SCREW		SCREW BAR
8	33592601	4		BICOCCIA BUCCHI		COLLETTI		FLANGE
9	03241500	2		VITI SOLLAUINI		VIT		SCRE WS
10	03386201	6		ROSETTA SCHELE		RONDELLI		WASHER?
11	03366300	2		DAVOLI MUTTER		CIRCU		NUT
12	03522004	2		MOLLA A GAS GASOLINO		RESORCE GAS		GAS SPRING
13	03385201	3		ROSETTA SCHELE		RONDELLI		WASHER?
14	03365100	4		DAVOLI MUTTER		CIRCU		NUT
15	23160062	1		RICONDIZIONE ANNOIAG		RECONDIT		REPAIR
16	13580321	1		SELE SILZ		SELE		SELE
17	63589413	1		GUIDA SILZJUNGHEIN		GUIDE		GUIDE
18	63589418	1		GUIDA SILZJUNGHEIN		GUIDE		GUIDE
19	63589414	1		GUIDA SILZJUNGHEIN		GUIDE		GUIDE
20	63589417	1		GUIDA SILZJUNGHEIN		GUIDE		GUIDE
21	13580322	1		CONDIZIONE SILZJUNGHEIN		CONDIZIONE		REPAIR
22	03240401	2		VITI SOLLAUINI		VIT		SCRE WS
23	03234802	2		VITI SOLLAUINI		VIT		SCRE WS
24	99050287	2		SUPPORTO LAMELLUNG		SUPPORT?		SUPP-CR?
25	03230601	4		VITI SOLLAUINI		VIT		SCRE WS

- ① IMPIANTO ELETTRICO: BATTERIA
- ② INSTALLATION ELECTRIQUE: BATTERIE
- ③ ELECTRIC SYSTEM: BATTERY
- ④ ELEKTRISCHE ANLAGE: BATTERIE

TAV. 08-01
96080053

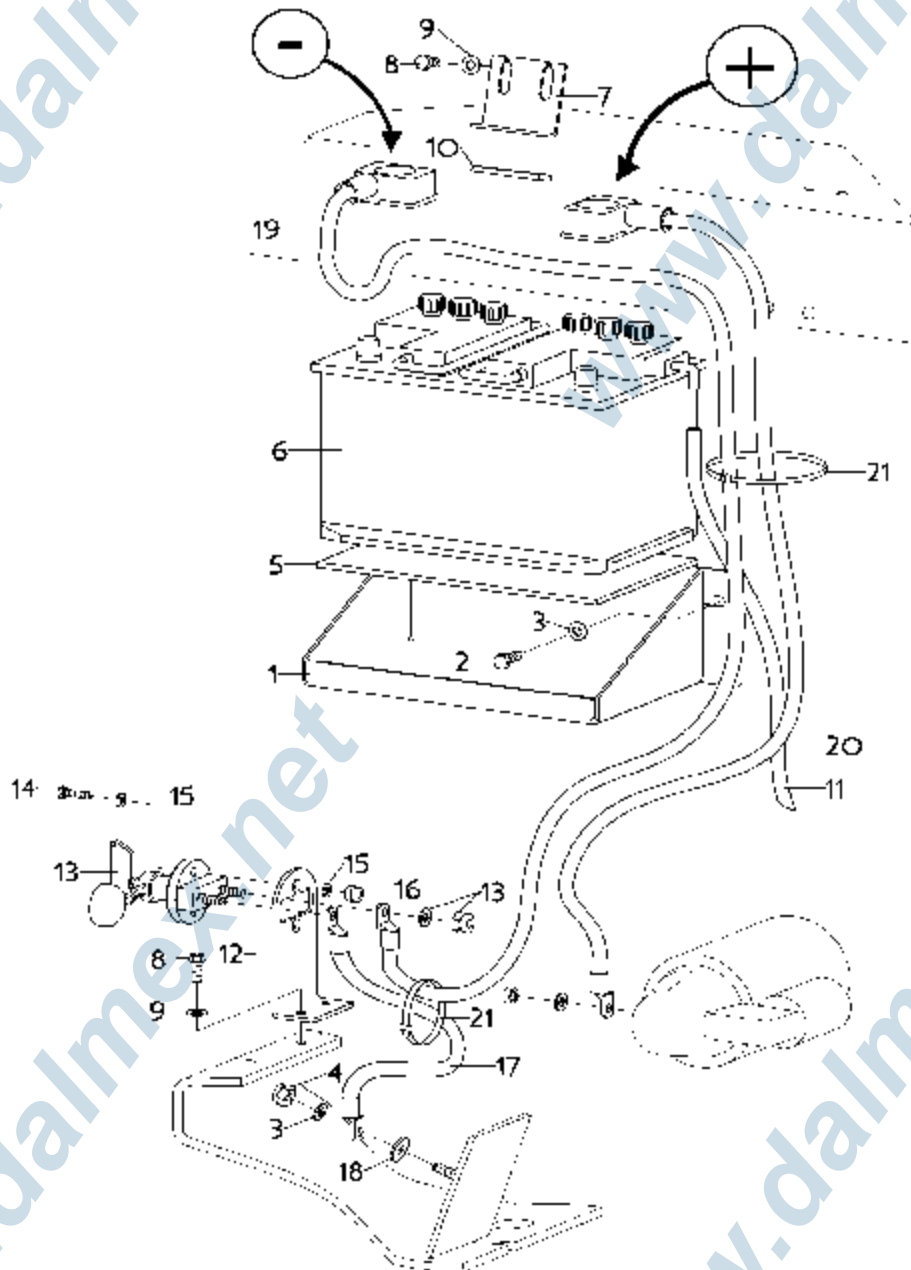



Tav. 08-01 - 96080053

P.	Codice	Q.	① ② Denominazione Benennung	③ Description	④ Description
1	45152474	1	SUPPORTO LAMELLUNG	SUPPORTO	SUP-032
2	03230301	2	VIT SOLICAMBI	VIT	SOLICAMBI
3	03385201	3	ROSETTA SCHELE	ROSETTE	WASHER
4	03365100	1	DAZO MULTIPLI	CIRCU	NUT
5	30013394	1	FROTTAGIONE SCHELE	FROTTAGION	FROTTAGION
6	03010011	1	BATTERIA BATTERIE	BATTERIE	BATTERY
7	45152413	1	STAMP FRASCHIO	FRASCHIO	CLAMP
8	03230501	4	VIT SOLICAMBI	VIT	SOLICAMBI
9	03385050	4	ROSETTA SCHELE	ROSETTE	WASHER
10	30013280	1	FROTTAGIONE SCHELE	FROTTAGION	FROTTAGION
11	27200319	1	LURO ROTTORI	LURO	P-PI
12	45152487	1	SUPPORTO LAMELLUNG	SUPPORTO	SUP-032
13	13470004	1	STRACOMBIATURA BATTERIA PER INDIRIZZAMENTO	STRACOMBIATURA	BATTERY DISCONNECTING CAM
14	03220701	2	VIT SOLICAMBI	VIT	SOLICAMBI
15	03385201	4	ROSETTA SCHELE	ROSETTE	WASHER
16	03364010	2	DAZO MULTIPLI	CIRCU	NUT
17	62473602	1	CAVOCACCIAVIT BATTERIA PER INDIRIZZAMENTO	CAVOCACCIAVIT	BATTERY DISCONNECTING CAM
18	03385401	1	ROSETTA SCHELE	ROSETTE	WASHER
19	62473601	1	CAVOCORONA MINUSPOLARE	CAVOCORONA	BATTERY POSITIVE CASE
20	03473231	1	CAVOCORONA PLUSPOLARE	CAVOCORONA	POSITIVE POLY CASE
21	13577200	4	FRASCIA SCHELE	FRASCIA	CAMP

- Ⓘ IMPIANTO ELETTRICO: TELAIO
- Ⓕ INSTALLATION ELECTRIQUE: CHASSIS
- Ⓖ ELECTRIC SYSTEM: FRAME
- Ⓓ ELECTRISCHE ANLAGE: CHASSIS

TAV. 08-02
96080054

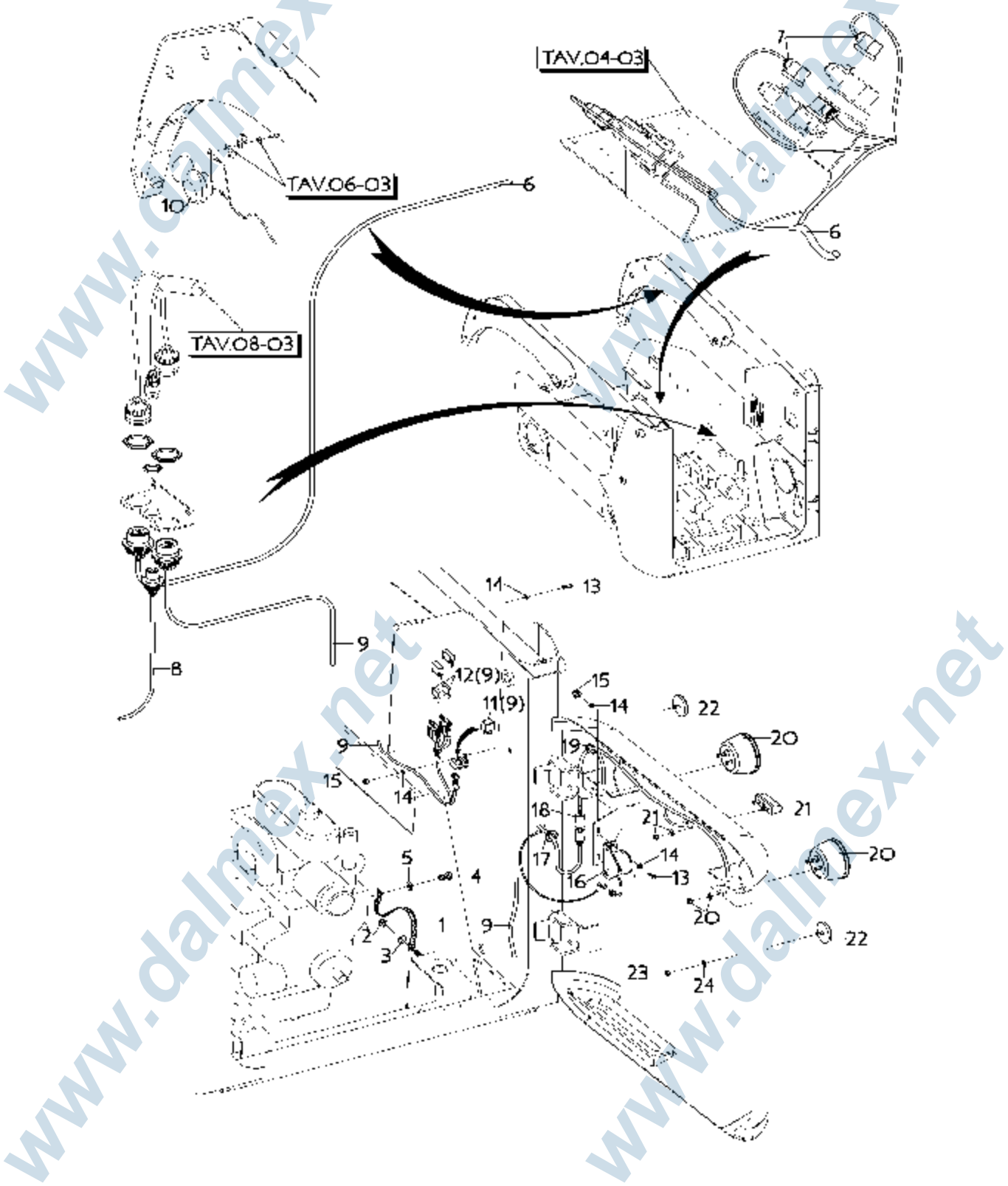

Tav. 08-02 - 96080054

P.	Codice	Q.	Ⓐ Ⓑ Denominazione Benennung	Ⓔ Description	Ⓖ Description
1	62473603	1	CAVOCMISSA A TITERS SICILIA S. TRUNGGAA	CALC. DI MIN. A. A. T. R.	LINE THING CAH I
2	03366001	1	DA 20 MUTTER	CIRCU	NLI
3	03386051	1	ROSI TA SCHILY	RONDELLI	WASILE ?
4	03250210	1	VI SCILMURI	VIS	SCILMURI
5	03387051	1	ROSI TA SCHILY	RONDELLI	WASILE ?
6	62473604	1	LINEA DI TRONCA VO LINEA DI TRONCA VO	SCORPIONE T. O. R. E. U.	SCILMURIA V. S. T. I. N. I
7	33185000	5	CONNETTORI V. S. T. I. N. I	CONNETTORI	CONNETTORI
8	62473605	1	LINEA ANTICORRUPZIONE LINEA ANTICORRUPZIONE	LINEA ANTICORRUPZIONE	LINEA ANTICORRUPZIONE
9	62473606	1	LINEA POS. ROZI LINEA POS. ROZI	LINEA POS. ROZI	LINEA POS. ROZI
10	03480900	1	ROMA ROMA	ROMA	ROMA
11	73472213	1	R. MIS. AV. AV. AV. AV. AV. R. MIS. AV. AV. AV. AV. AV.	R. MIS. AV. AV. AV. AV. AV.	R. MIS. AV. AV. AV. AV. AV.
12	72482416	2	LINEA DI TRONCA VO LINEA DI TRONCA VO	LINEA DI TRONCA VO	LINEA DI TRONCA VO
13	03225000	2	VI SCILMURI	VIS	SCILMURI
14	03383201	5	ROSI TA SCHILY	RONDELLI	WASILE ?
15	03364010	3	DA 20 MUTTER	CIRCU	NLI
16	72482207	1	LINEA ANTICORRUPZIONE LINEA ANTICORRUPZIONE	LINEA ANTICORRUPZIONE	LINEA ANTICORRUPZIONE
17	03480017	1	FASCIA FASCIA	FASCIA	FASCIA
18	62473607	1	LINEA ANTICORRUPZIONE LINEA ANTICORRUPZIONE	LINEA ANTICORRUPZIONE	LINEA ANTICORRUPZIONE
19	13577200	4	FASCIA SCHILY	FASCIA	FASCIA
20	64571803	2	FASCIA FASCIA	FASCIA	FASCIA
21	64572100	1	FASCIA FASCIA	FASCIA	FASCIA
22	33578000	2	CAVOCMISSA A TITERS CAVOCMISSA A TITERS	CAVOCMISSA A TITERS	CAVOCMISSA A TITERS
23	03363001	2	DA 20 MUTTER	CIRCU	NLI
24	03381000	2	ROSI TA SCHILY	RONDELLI	WASILE ?

- Ⓘ IMPIANTO ELETTRICO: CABINA
- Ⓕ INSTALLATION ELECTRIQUE: CABINE
- Ⓖ ELECTRIC SYSTEM: CAB
- Ⓓ ELEKTRISCHE ANLAGE: KABINE

TAV. 08-03
96080055

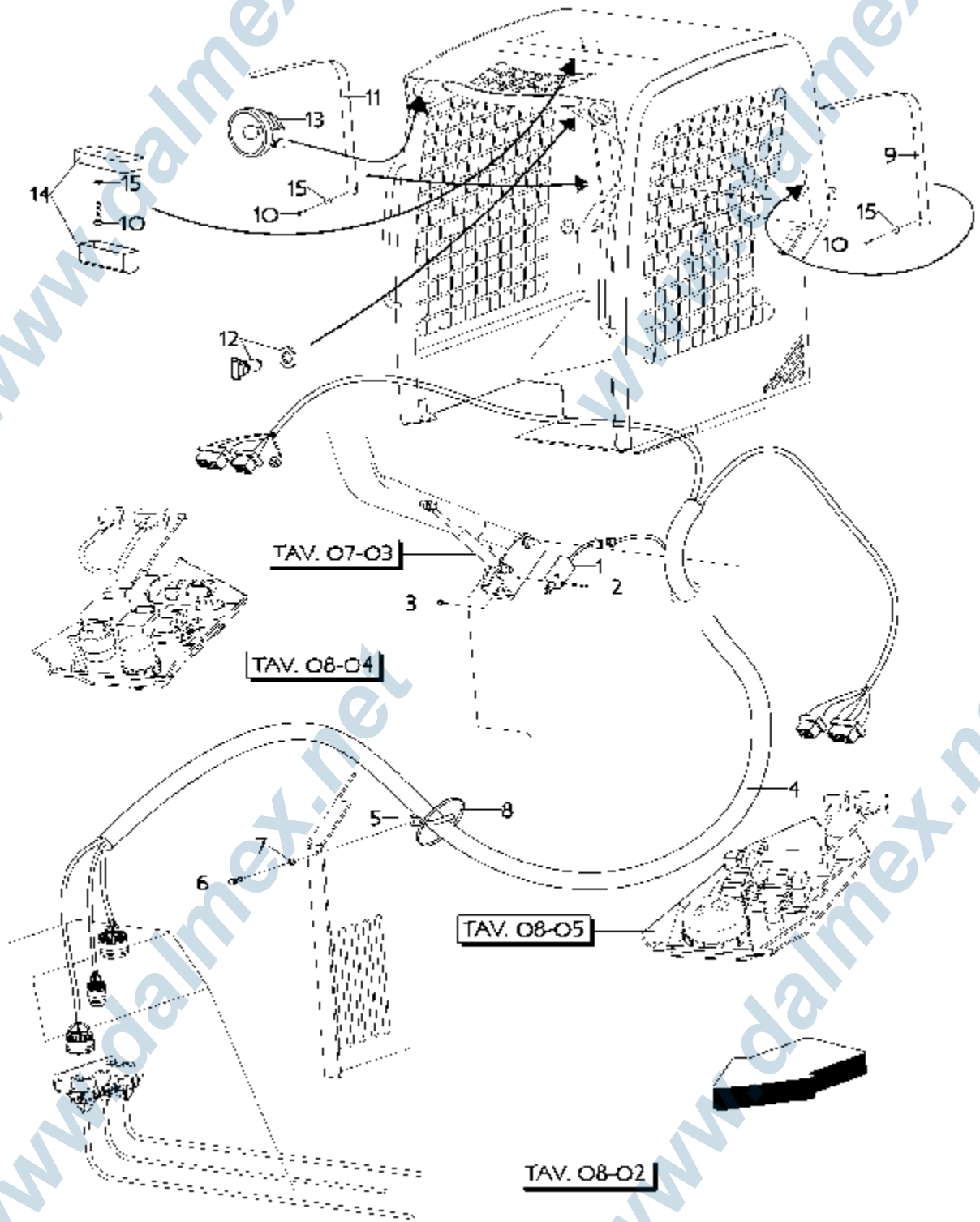



Tav. 08-03 - 96080055

P.	Codice	Q.	① ②	Denominazione Benennung	③	Description	④	Description
1	13470702	1	①	LINIA CORSA LINDANSOL AG	③	LIND CORRSI	④	LIND SW CIT
2	03204600	2	②	VII SCHRAUB	③	VIS	④	SCRE WS
3	03362100	2	②	DA 30 MUTTER	③	ORCUI	④	NUT
4	62473608	1	①	LINIA POSI 03GLIDA LAMBRETTA INT	③	IGN POSI 03 CONDU T	④	DRIVING PACE INT
5	45500145	1	①	SEMPRE TRAGHIO	③	L R I T	④	CLAMP
6	03220401	1	②	VII SCHRAUB	③	VIS	④	SCRE WS
7	03383000	1	①	ROSETTA SCHULTZ	③	RONDELLI	④	WASHER
8	13572201	1	①	LASCIA SCHULTZ	③	WIDE	④	COVER
9	30013466	1	①	FROTTIZIONE SCHULTZ	③	FROTTIZIONE	④	FROTTIZIONE
10	03209710	10	②	VII SCHRAUB	③	VIS	④	SCRE WS
11	30013465	1	①	FROTTIZIONE SCHULTZ	③	FROTTIZIONE	④	FROTTIZIONE
12	33470600	1	①	FRASER SERVICE B. TRIBB	③	FRAS SERVICE	④	FUNCTION PILE
13	74572708	2	②	LAVORO KUBITZSCH TULLI	③	TULLI RAVAT	④	WORKING SET
14	72572709	1	①	FRANCIERA DOK N APPI	③	FRANCIERE	④	ROCK WIP
15	03380500	10	②	ROSETTA SCHULTZ	③	RONDELLI	④	WASHER

- ① IMPIANTO ELETTRICO: CRUSCOTTO DESTRO
- ② INSTALLATION ELECTRIQUE: TABLEAU DE BORD DROIT
- ③ ELECTRIC SYSTEM: RIGHT CONTROL PANEL
- ④ ELEKTROANLAGE: RECHTES INSTRUMENTENBRETT

TAV. 08-04
96080048

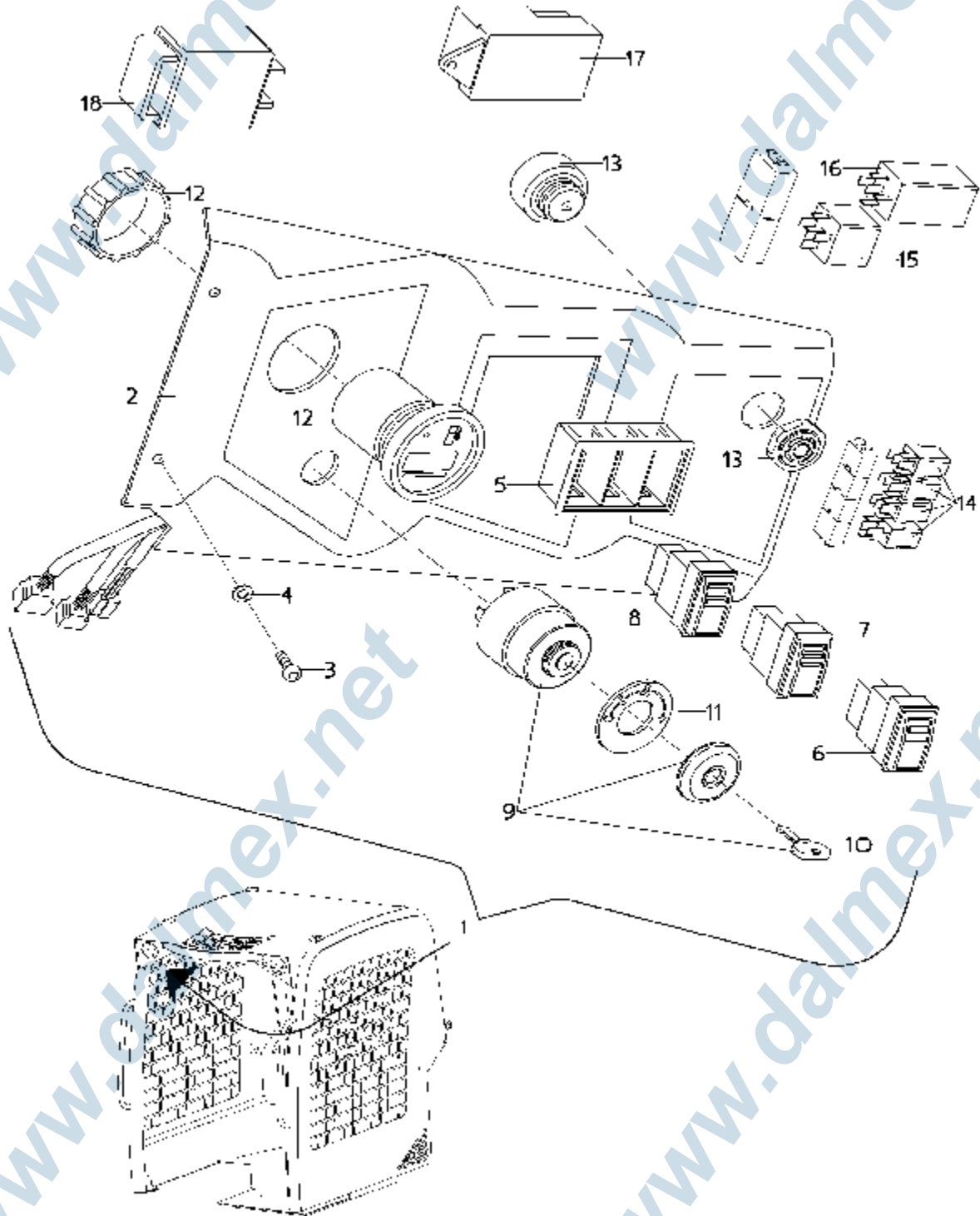



- Ⓘ IMPIANTO ELETTRICO: CRUSOTTO SINISTRO
- Ⓕ INSTALLATION ELECTRIQUE: TABLEAU DE BORD GAUCHE
- ⒼⒸ ELECTRIC SYSTEM: LEFT CONTROL PANEL
- Ⓓ ELECTROANLAGE: LINKES INSTRUMENTENBRETT

TAV. 08-05
96080049

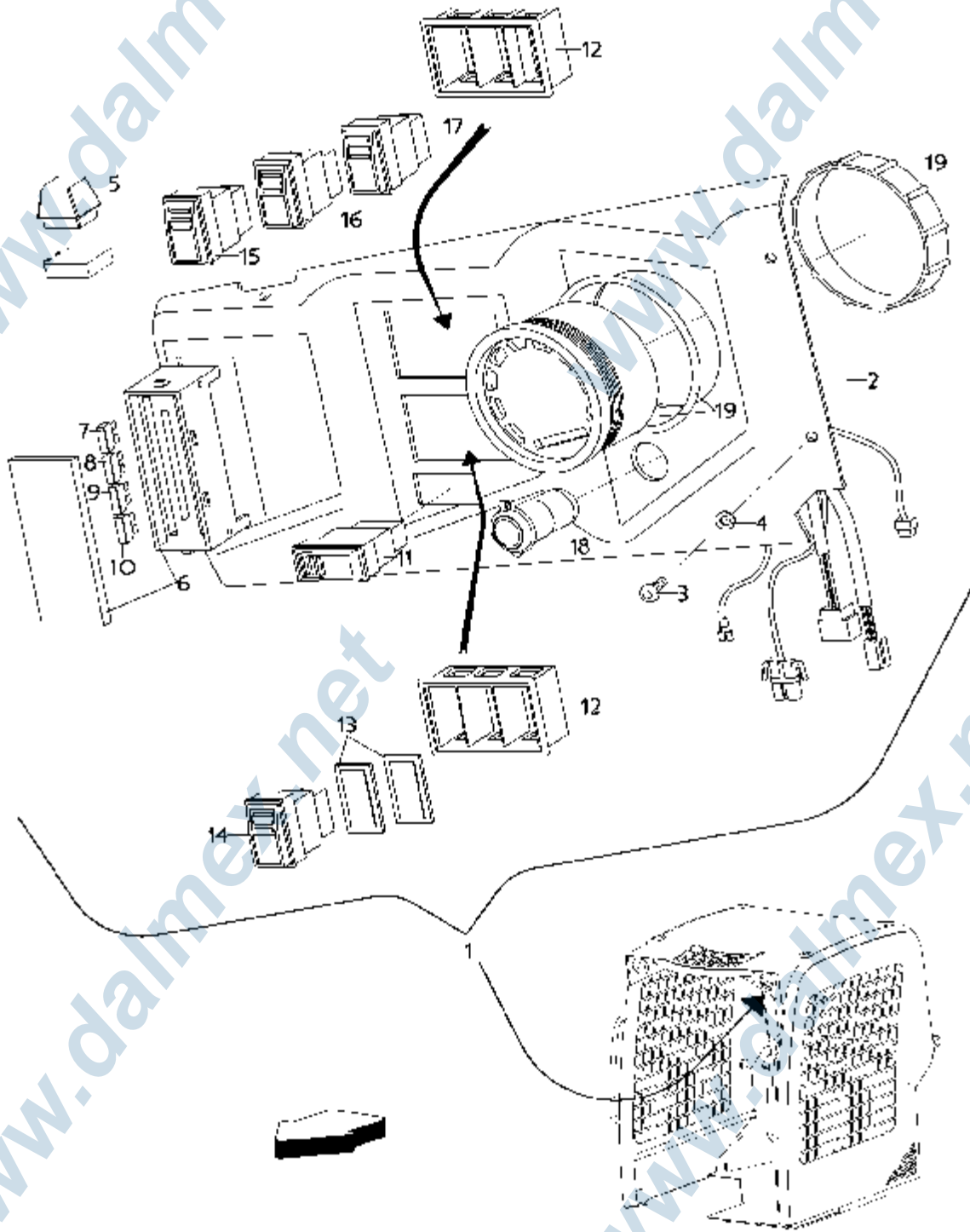

www.dalmex.net

www.dalmex.net



Tav. 08-05 - 96080049

P.	Codice	Q.	① ② Denominazione Benennung	③ Description	④ Description
1	64485007	1	GRUPPO DI COMPONENTI KOMPLETTES BAUELEMENTENSET	ASSEMBLY OF COMPONENTS	BASE COMPONENT
2	13647219	1	GRUPPO DI BAUELEMENTENSET	ASSEMBLY OF	BASE COMPONENT
3	03227700	4	VITTE SCHRAUBEN	WASHER	SCREW
4	03383201	4	ROSETTA SCHLEIF	ROSETTE	WASHER
5	72482201	1	INSTRUMENTAZIONE AUSSTATTUNG	INSTRUMENT	INSTRUMENT
6	67480004	1	SOCCO A PORTA USATE SCHLEIFKABELSCHLEIF	SOCKET PORT USABLE	PLUG CONTACT
7	72482414	5	USCITA 5A SCHLEIFKABELSCHLEIF 5A	USING 5A	5A PLUG
8	67480080	2	USCITA 7.5A SCHLEIFKABELSCHLEIF 7.5A	USING 7.5A	PLUG 7.5A
9	67480001	5	USCITA 10A SCHLEIFKABELSCHLEIF 10A	USING 10A	PLUG 10A
10	67480002	2	USCITA 15A SCHLEIFKABELSCHLEIF 15A	USING 15A	15A PLUG
11	63472949	1	INSTRUMENTAZIONE PER SCHLEIFKABELSCHLEIF	INSTRUMENT CONTACTS OF	DIRECTIONAL CONTACT SWITCH
12	63479000	2	FOR ANTERIOR SCHLEIFKABELSCHLEIF	FOR ANTERIOR	SWITCH CONTACT
13	63480000	2	APPRETO STOPPEN	HOOK ON	PLUG
14	63472950	1	INSTRUMENTAZIONE SCHLEIFKABELSCHLEIF	INSTRUMENT CONTACTS	LIGHT SWITCH
15	63472951	1	INSTRUMENTAZIONE SCHLEIFKABELSCHLEIF	INSTRUMENT CONTACTS	WORKING LIGHT SWITCH
16	63472952	1	INSTRUMENTAZIONE RUNDUMKONTAKTLEISTEN	INSTRUMENT CONTACTS	WORKING LIGHT SWITCH
17	63472953	1	INSTRUMENTAZIONE KONTAKTLEISTEN	INSTRUMENT CONTACTS	WORKING LIGHT SWITCH
18	74470608	1	PER SERVIZIO BETRIEB	FOR SERVICE	FUNCTION PLUG
19	64485008	1	GRUPPO DI COMPONENTI KOMPLETTES BAUELEMENTENSET	ASSEMBLY OF COMPONENTS	COMPLETE BAUELEMENT



- ① TARGHETTE
- ⓕ PLAQUETTES
- ⓐ LABELS
- ⓓ SCHILDEN

TAV. 09-01
96090072

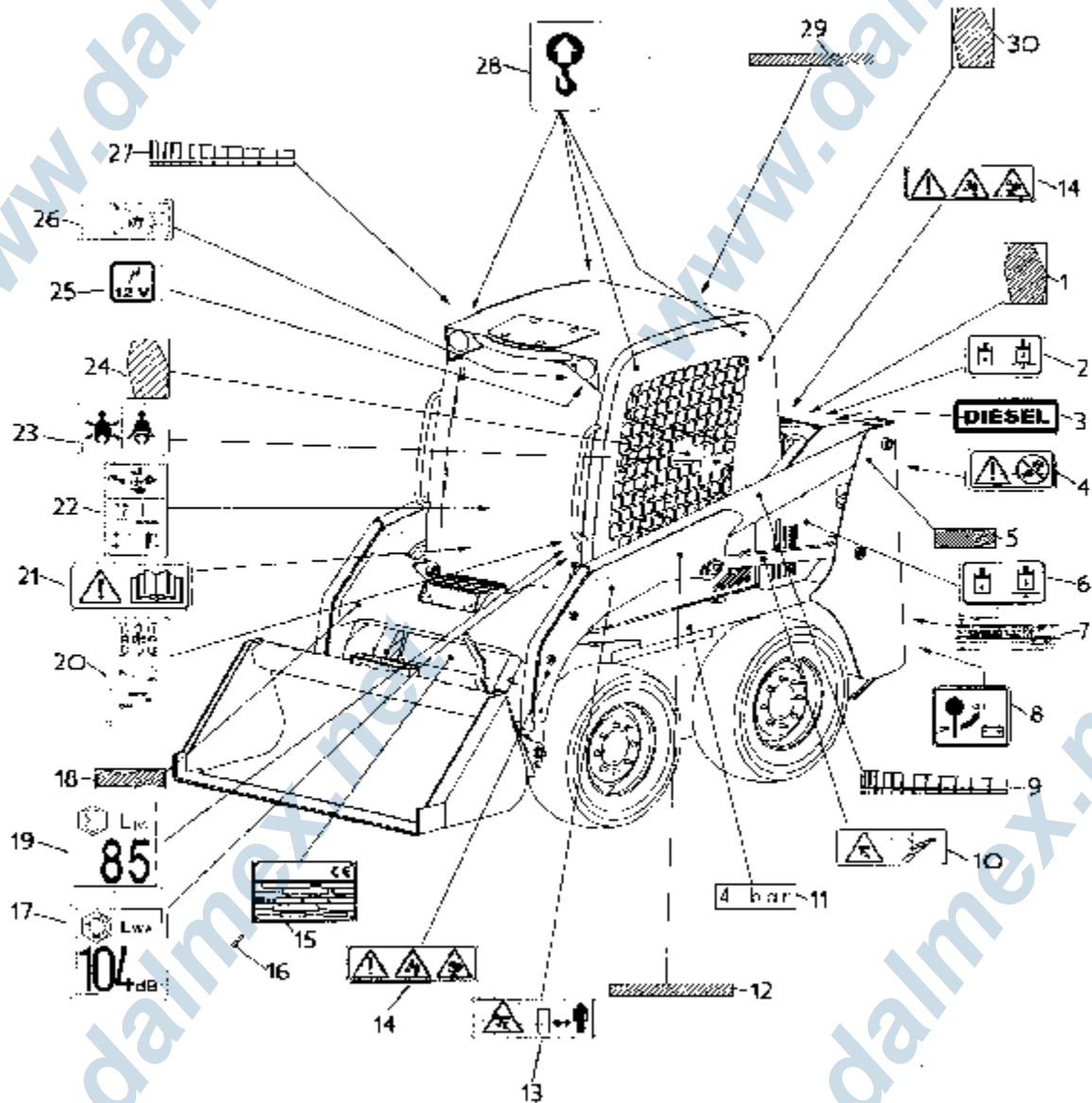



Tav. 09-01 - 96090072

P.	Codice	Q.	Ⓐ Ⓑ	Denominazione Benennung	Ⓔ	Description	ⒼⒷ	Description
1	03660119	1	Ⓐ	A 2301 11A COSTRUZIONE SEC II D II RS 2	PLACI	11 COSTRUZIONE	MANUFATTURE 23 PL A 1	
2	03660086	1	Ⓐ	A 2301 11A SEC II D	PLACI	11	23 PL	
3	03660149	1	Ⓐ	A 2301 11A SEC II D	PLACI	11	23 PL	
4	03660169	1	Ⓐ	A 2301 11A SEC II D	PLACI	11	23 PL	
5	03664854	2	Ⓐ	A 2301 11A COSTRUZIONE SEC II D II RS 2	PLACI	11 COSTRUZIONE	MANUFATTURE 23 PL A 1	
6	03660005	1	Ⓐ	A 2301 11A SEC II D	PLACI	11	23 PL	
7	03664402	1	Ⓐ	A 2301 11A SEC II D	PLACI	11	23 PL	
8	03660160	1	Ⓐ	A 2301 11A SEC II D	PLACI	11	23 PL	
9	03664856	1	Ⓐ	A 2301 11A SEC II D	PLACI	11	23 PL	
10	03660082	1	Ⓐ	A 2301 11A SEC II D	PLACI	11	23 PL	
11	03663006	2	Ⓐ	A 2301 11A SEC II D	PLACI	11	23 PL	
12	03660124	2	Ⓐ	A 2301 11A COSTRUZIONE SEC II D II RS 2	PLACI	11 COSTRUZIONE	MANUFATTURE 23 PL A 1	
13	03660098	2	Ⓐ	A 2301 11A SEC II D	PLACI	11	23 PL	
14	03660099	3	Ⓐ	A 2301 11A SEC II D	PLACI	11	23 PL	
15	03664801	1	Ⓐ	A 2301 11A VATERKOLA SEC II D K NKL VM 2	PLACI	11 VATERKOLA	23 PL NUMER PL A	
16	03449900	4		REMI T C MI	23	1	REMI T	
17	03665017	1	Ⓐ	A 2301 11A SEC II D	PLACI	11	23 PL	
18	03664852	1	Ⓐ	A 2301 11A SEC II D	PLACI	11	23 PL	
19	03665013	1	Ⓐ	A 2301 11A SEC II D	PLACI	11	23 PL	
20	03666192	1	Ⓐ	A 2301 11A SEC II D	PLACI	11	23 PL	
21	03660170	1	Ⓐ	A 2301 11A SEC II D	PLACI	11	23 PL	
22	03666193	1	Ⓐ	A 2301 11A SEC II D	PLACI	11	23 PL	
23	03666048	1	Ⓐ	A 2301 11A SEC II D	PLACI	11	23 PL	
24	03660113	1	Ⓐ	A 2301 11A COSTRUZIONE SEC II D II RS 2	PLACI	11 COSTRUZIONE	MANUFATTURE 23 PL A 1	
25	03666049	1	Ⓐ	A 2301 11A SEC II D	PLACI	11	23 PL	
26	03660191	1	Ⓐ	A 2301 11A SEC II D	PLACI	11	23 PL	
27	03664855	1	Ⓐ	A 2301 11A SEC II D	PLACI	11	23 PL	
28	03666024	4	Ⓐ	A 2301 11A SEC II D	PLACI	11	23 PL	
29	03665400	1	Ⓐ	A 2301 11A COSTRUZIONE SEC II D II RS 2	PLACI	11 COSTRUZIONE	MANUFATTURE 23 PL A 1	
30	03660117	2	Ⓐ	A 2301 11A COSTRUZIONE SEC II D II RS 2	PLACI	11 COSTRUZIONE	MANUFATTURE 23 PL A 1	



- ① ATTREZZI DI SERVIZIO – DOTAZIONI
- ② OUTILLAGES DE SERVICE – ACCESSOIRES
- ③ SERVICE TOOLS – EQUIPMENTS
- ④ BETRIEBSWERKZEUGE – AUSRÜSTUNG

TAV. 09-02

96090073

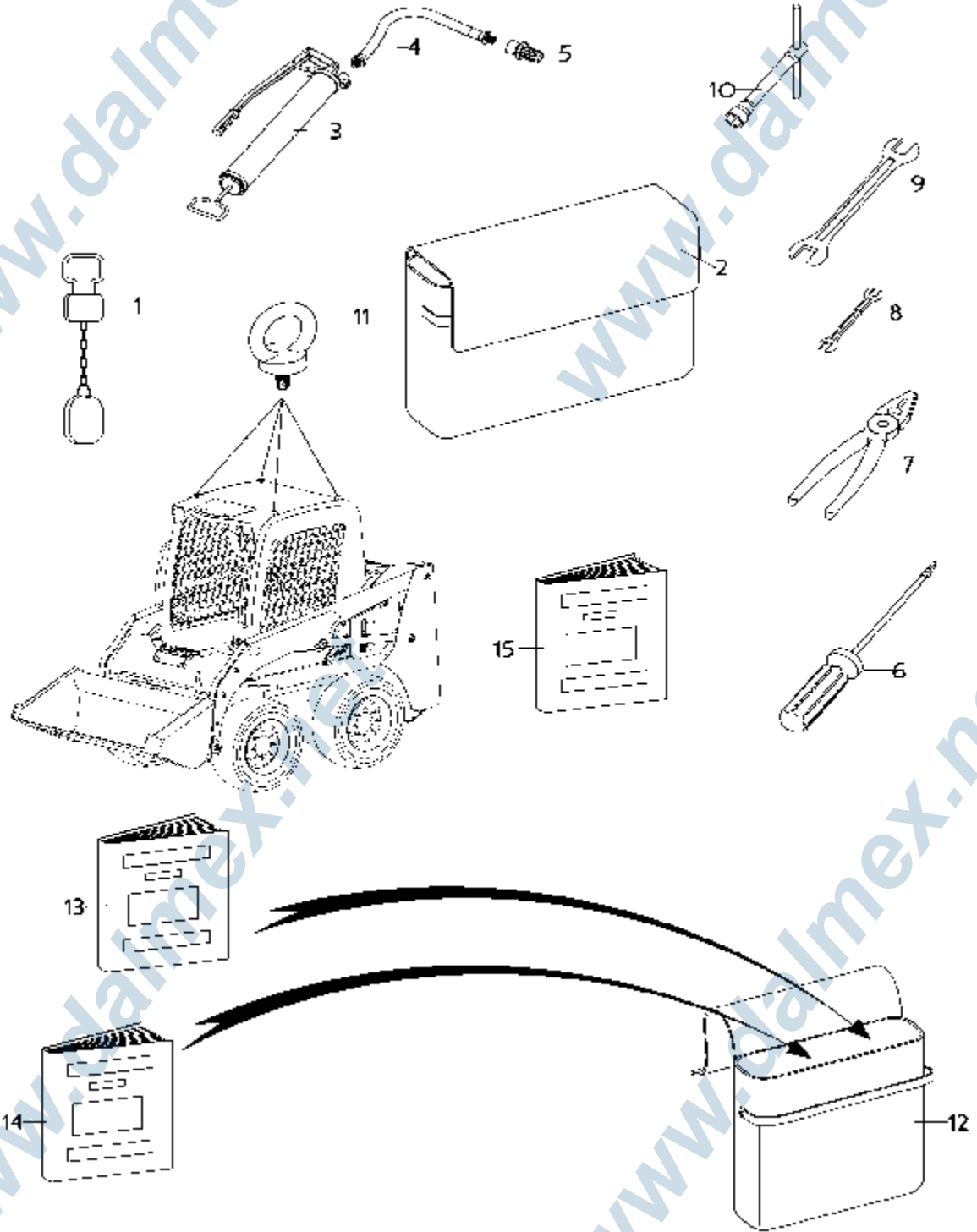



Tav. 09-02 - 96090073

P.	Codice	Q.	Ⓐ Ⓑ Denominazione Benennung	Ⓔ Description	ⒼⒸ Description
1	03573000	1	FORIACI AVE SOI LUSSE LAMI ANGLE	FORI CUTS	KEY RING
2	03679000	1	BUS A UMSCHLAGE	TRCULSSI	KEY R
3	03519600	1	FOVPA G RANNO SOI M INPUMET	COMP A GRAISS	GRABING PUMP
4	03519800	1	URO ROU R	JYAU	F-PI
5	03519900	1	LEINA ONKOP	LI	LIAD
6	03572000	1	GIRAVI SOI RAJIN NSOI LUSSE	COLNMI VE	SOI R VOR VITR
7	03572300	1	FNA ZANSE	TRER	RIPETI
8	03570000	1	GI IAVI 10 13 mm SOI LUSSE 10 13 mm	GI 10 13 mm	K 10 13 mm
9	03571000	1	GI IAVI 17 19 mm SOI LUSSE 17 19 mm	GI 17 19 mm	K 17 19 mm
10	03571510	1	GI IAVI 24 mm SOI LUSSE 24 mm	GI 24 mm	KEY 24 mm
11	03351201	4	GOI AIR TRANS-AD FICCHI	A. ILLISSI DI SOIUI VI VENTI	LI ING NKAG
12	03679700	1	BUS A UMSCHLAGE	TRCULSSI	KEY R
13	03671801	1	CA A DGO PAR TOUNICAMLEO LIRSA ZI LKA RICE	CATALOGL FI CUSI DI FACI LIS	PAR SCATALOGL
14	03671603	1	MANUA BEMANU NZ RIRANVA L AN DUCI LIR VVA R LING UNO R PARAL R	L V R D I N I R D I N I L I R P A R A T I O N	MANI KAVI WORKS IOP MBLA
15	03671602	1	MANUA OPERATOR G BAJUKISAN TUNGSULGI	L V R D I N I R D I	JUSI ICS MBLA

- Ⓛ VALVOLA ALTO LIVELLANTE
- ⓕ VALVE AUTO-NIVELLEUSE
- ⓐ SELFLEVELLING VALVE
- ⓓ SELBSTNIVELLIERUNGSVENTIL

TAV. 10-01
96100094

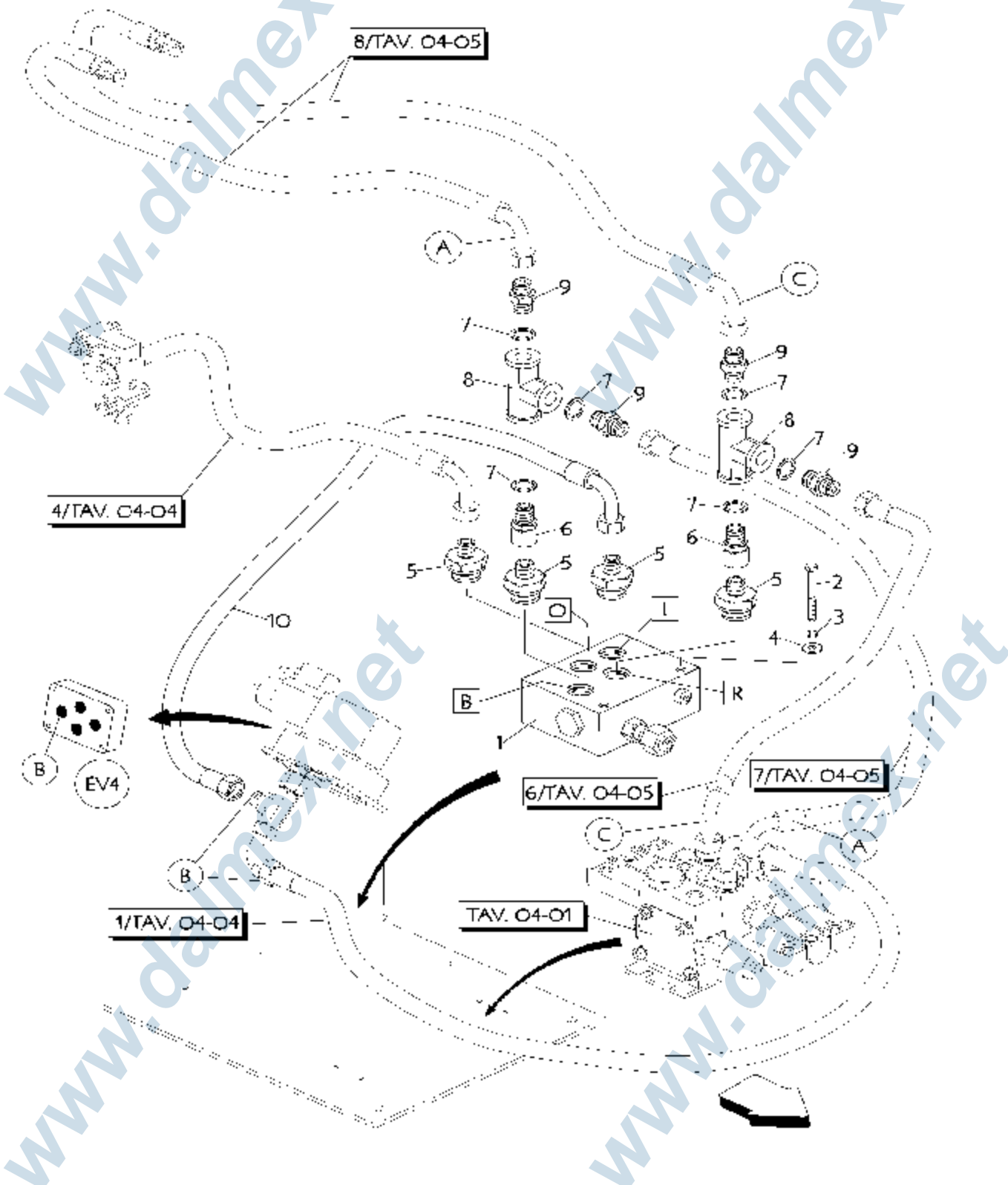



Tav. 10-01 - 96100094

P.	Codice	Q.	Ⓐ Ⓑ	Denominazione Benennung	Ⓔ	Description	ⒼⒷ	Description
1	13842900	1	VA VO A V N III	VALVOLE VANTILI		SOLENOI	SOLENOI	
2	03221400	2	VII SOLINAUM	VII SOLINAUM		VIS	SOLENOI	
3	03383000	2	ROSI TA SOI III	ROSI TA SOI III		RONDELLI	WASHER	
4	03383311	2	ROSI TA SOI III	ROSI TA SOI III		RONDELLI	WASHER	
5	13160211	4	RACCORDO ANSO L USS	RACCORDO ANSO L USS		RACCORDO	CONNECTION	
6	13150000	2	RACCORDO ANSO L USS	RACCORDO ANSO L USS		RACCORDO	CONNECTION	
7	03168200	6	GIAMBI / ONI DICI LINEE	GIAMBI / ONI DICI LINEE		GIAMBI / ONI	GRABER	
8	03639810	2	GIUNZIONI V TERNIUNG	GIUNZIONI V TERNIUNG		ASSI MUNG	LINKER	
9	13152800	4	RACCORDO ANSO L USS	RACCORDO ANSO L USS		RACCORDO	CONNECTION	
10	03111850	1	URO ROTORI	URO ROTORI		URO	R-PI	



- Ⓢ OMOLOGAZIONE STRADALE
- ⓕ HOMOLOGATION SUR RUE
- ⓐ STREET HOMOLOGATION
- Ⓝ STRASSENZULASSUNG

TAV. 10-02
96100125

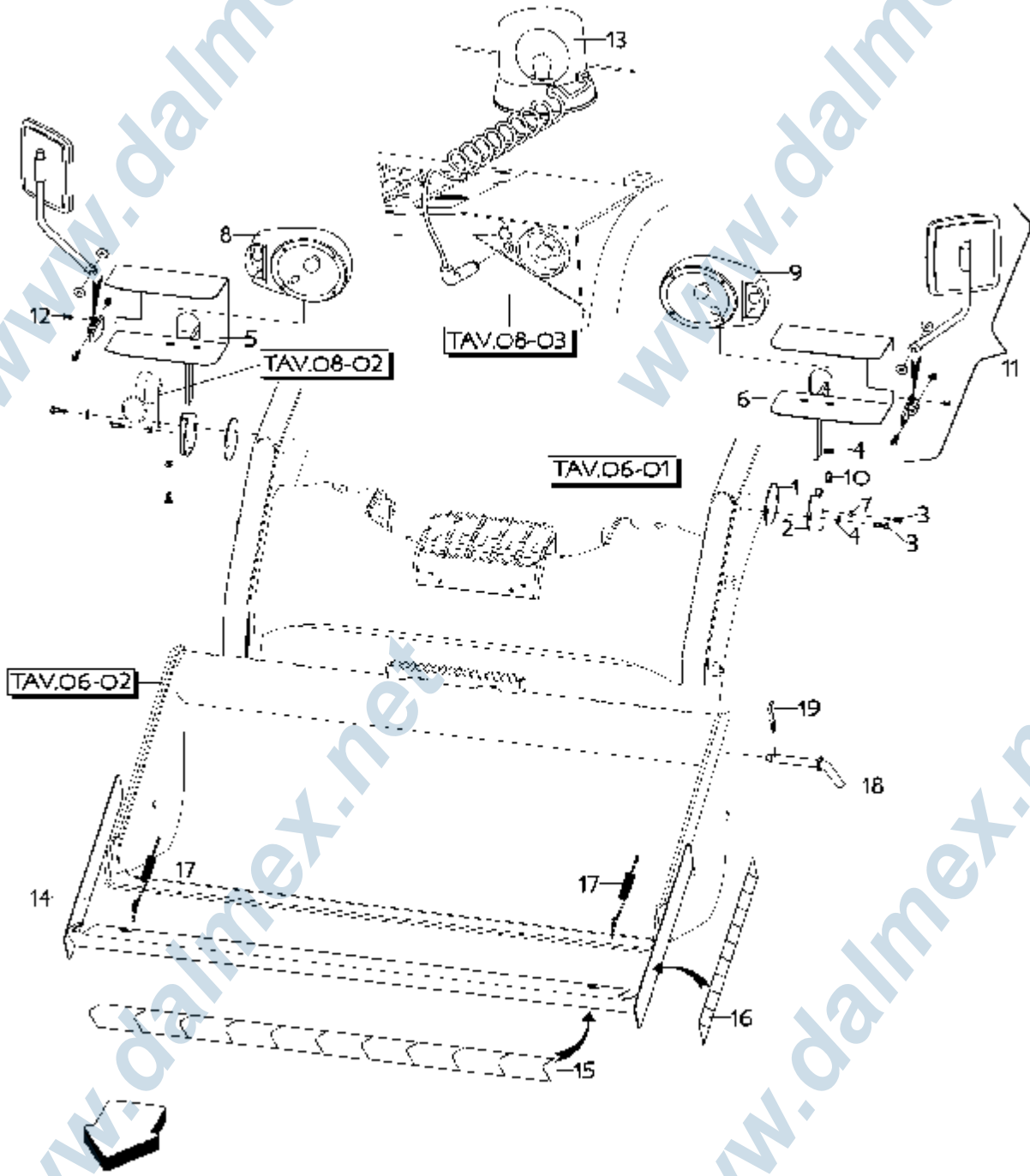



Tav. 10-02 - 96100125

P.	Codice	Q.	Ⓛ Ⓜ	Denominazione Benennung	Ⓟ	Description	Ⓤ	Description
1	45152480	2		BASIS	Ⓟ	BASIS	Ⓤ	BASIS
2	45152477	2		BASIS GUIDA SILIZIUMSILICONE	Ⓟ	GUIDE	Ⓤ	GUIDE
3	03230601	6		VIT	Ⓟ	VIT	Ⓤ	SCREW
4	03385050	3		SCORRIBILI ROSCHE SCELLE	Ⓟ	ROUNDS	Ⓤ	WASHER
5	45152478	1		SUPPORTO LATERALE	Ⓟ	SUPPORT	Ⓤ	SUPPORT
6	45152479	1		SUPPORTO LATERALE	Ⓟ	SUPPORT	Ⓤ	SUPPORT
7	03365001	2		BASE MUTTER	Ⓟ	ORBIT	Ⓤ	NUT
8	33571202	1		LAMP LAMPSCHEINWERKER	Ⓟ	LAMP	Ⓤ	LAMP SOCKET
9	33571203	1		LAMP LAMPSCHEINWERKER	Ⓟ	LAMP	Ⓤ	LAMP SOCKET
10	03230501	4		VIT	Ⓟ	VIT	Ⓤ	SCREW
11	99C60002	2		SPACCO SPACE	Ⓟ	WASHER	Ⓤ	WASHER
12	03226001	6		VIT	Ⓟ	VIT	Ⓤ	SCREW
13	33570015	1		LAMP A LUCE LAMPSCHEINWERKER LAMPSCHEINWERKER	Ⓟ	LAMP SOCKET	Ⓤ	LAMP SOCKET
14	30013387	1		PROTEZIONE SCHUTZ	Ⓟ	PROTECTION	Ⓤ	PROTECTION
15	99800219	1		PLACCA SCHEIBE	Ⓟ	PLATE	Ⓤ	PLATE
16	99800215	2		PLACCA SCHEIBE	Ⓟ	PLATE	Ⓤ	PLATE
17	03733700	2		MORSA KLEBE	Ⓟ	WASHER	Ⓤ	WASHER
18	45C71089	2		PISTO BOGEN	Ⓟ	PISTON	Ⓤ	PISTON
19	03739800	2		COFFRINO SPINN	Ⓟ	COUPLER	Ⓤ	SPINNING



- ① PEDALE ACCELERATORE
- ② PEDALE D'ACCELERATEUR
- ③ ACCELERATOR PEDAL
- ④ GASPEDAL

TAV. 10-03

96100096

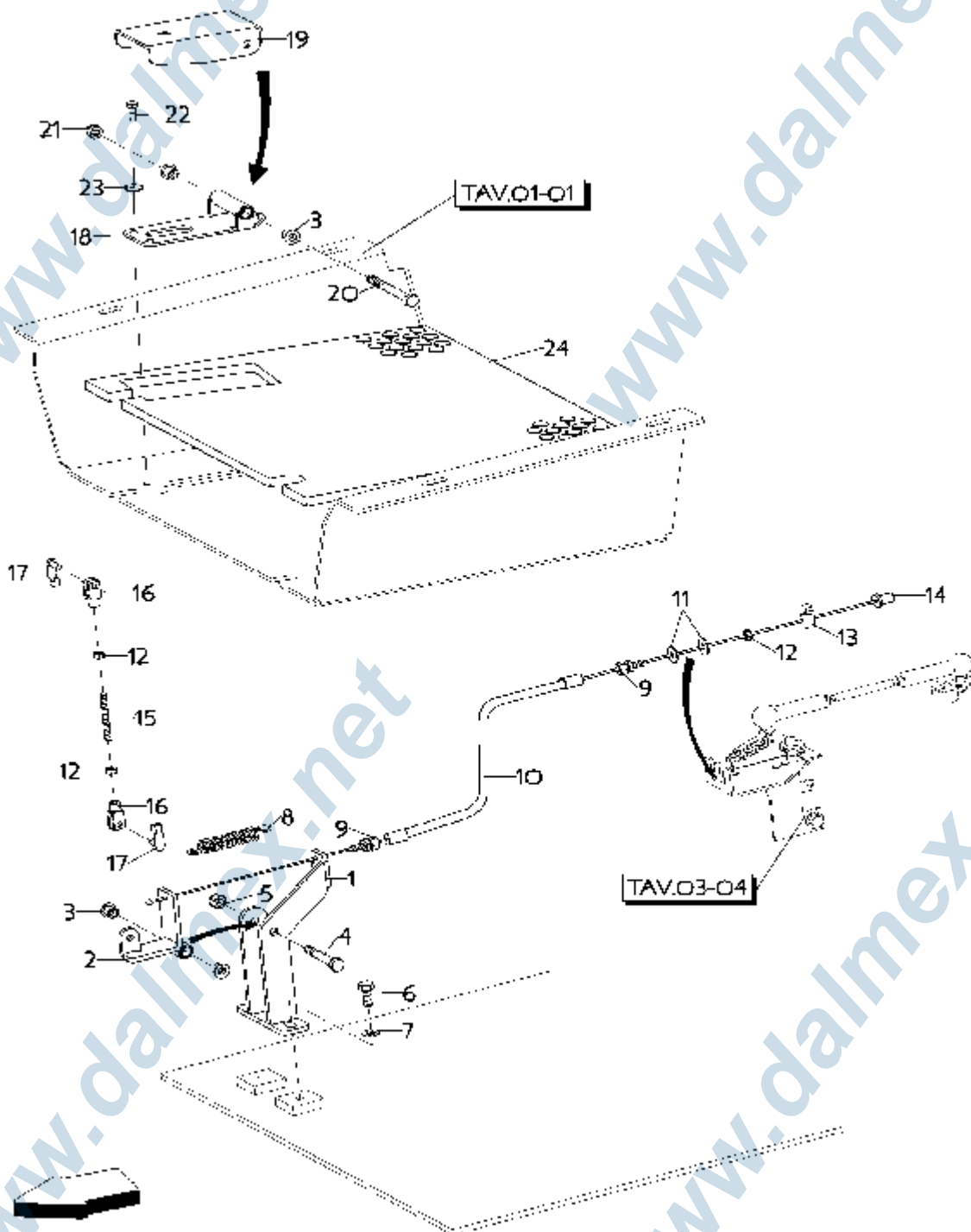



Tav. 10-03 - 96100096

P.	Codice	Q.	Ⓐ Ⓑ	Denominazione Benennung	Ⓕ	Description	Ⓖ	Description
1	23250025	1		SUPPORTO LAMELLUNG		SUPPORT		SUP-OR
2	23250021	1		LEVA LEVA		LEVER		LEVER
3	33592600	4		BROCCIA BROCCIA		COLLET		COLLET
4	03231200	1		VITE SOLLAU		WASHER		SCREW
5	03365100	1		DADE MUTTER		ORCO		NUT
6	03234701	2		VITE SOLLAU		WASHER		SCREW
7	03385201	2		ROSETTA SCHELE		RONDELLI		WASHER
8	03732001	1		MOTORE LEVA		FRANCO		FRANCO
9	03563000	2		FRANCO ZUGLEDER		FRANCO		ADJUSTER
10	03561303	1		CAVO KAB		CAV		CABLE
11	03385311	2		ROSETTA SCHELE		RONDELLI		WASHER
12	03364001	3		DADE MUTTER		ORCO		NUT
13	03563800	1		MOTORE KAB		LEVA		CLAMP
14	03460610	1		LEVA KAB		FRANCO X R.M.T. CAB		FRANCO
15	23250035	1		FRANCO FRANCO		FRANCO		FRANCO
16	13430006	2		FRANCO FRANCO		FRANCO		FRANCO
17	13439565	1		FRANCO FRANCO		FRANCO		FRANCO
18	23250029	1		SUPPORTO LAMELLUNG		SUPPORT		SUP-OR
19	23250032	1		FRANCO FRANCO		FRANCO		FRANCO
20	03231701	1		VITE SOLLAU		WASHER		SCREW
21	03365150	1		DADE MUTTER		ORCO		NUT
22	03220401	3		VITE SOLLAU		WASHER		SCREW
23	03385201	3		ROSETTA SCHELE		RONDELLI		WASHER
24	30060461	1		FRANCO FRANCO		FRANCO		FRANCO



- ① FORCA PALLET
- ② FOURCHE POUR PALLET
- ③ PALLET FORK
- ④ PALLETGABEL

TAV. 10-04

96100097

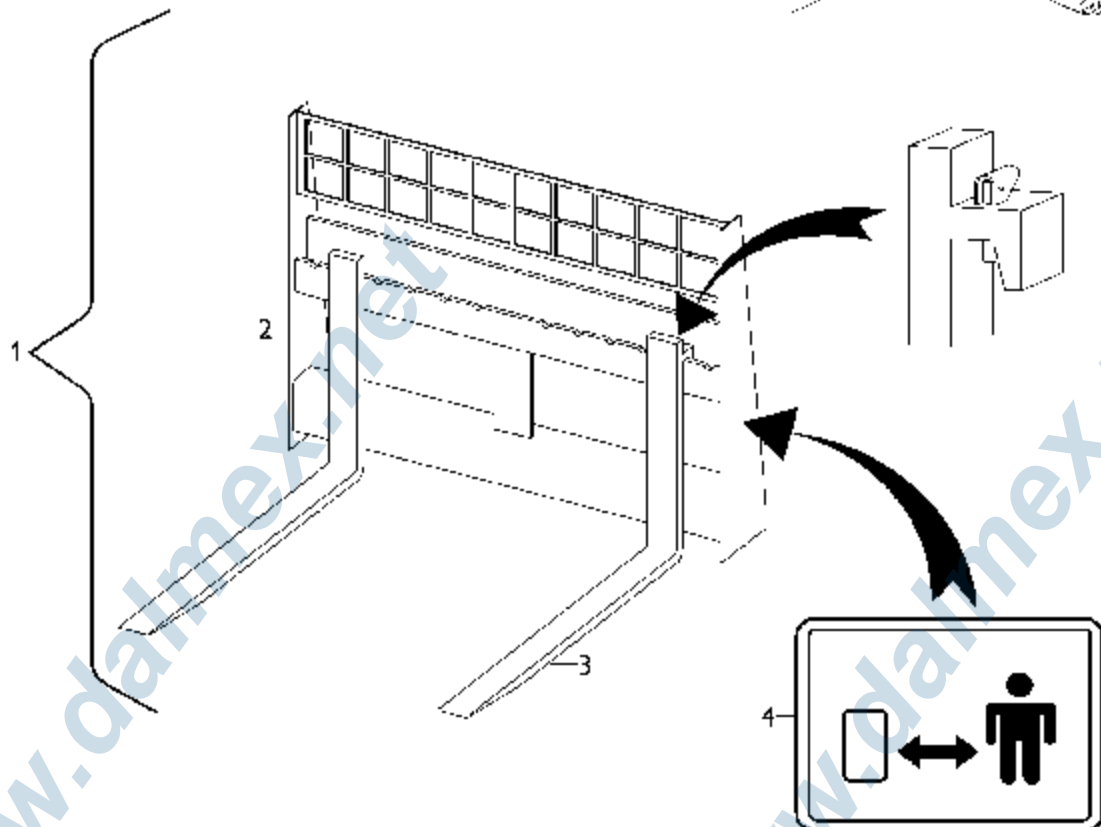
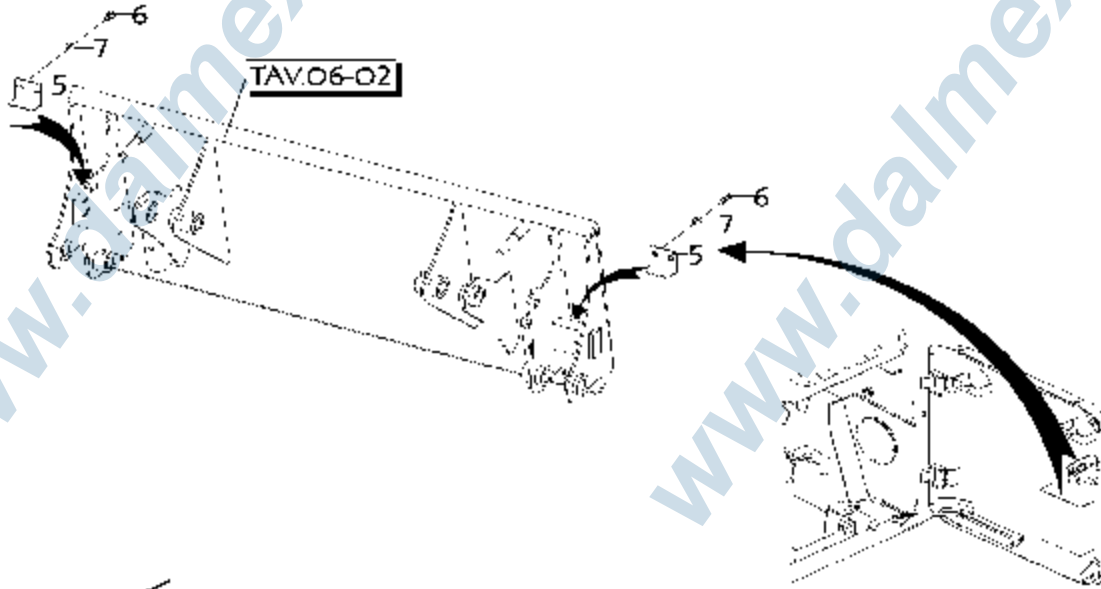



Tav. 10-04 - 96100097

P.	Codice	Q.	Ⓘ Ⓛ Denominazione Ⓛ Benennung	Ⓕ Description	Ⓖ Description
1	13642550	1	LENGA COMP. LA KOMPLETE GARNI	CLUR II COMPLETE	COMPLETE LORK
2	63642500	1	AL ACCO RAPIDO SCHEM. I COUPLINGE	A. II LARGI SCHEM.	QUICK COUPLINGE
3	63642501	2	LENGA GARNI	CLUR II	LORK
4	62660000	2	K. LARGI II II SALZ. SCHEM. I DER	KII PLACQUE	KII PLATES
5	55C90081	2	RIBONITAC ANNO II AG	I. DITTA II	TRABE I
6	03230301	4	VII SCHEM. II	VII	SCHEM.
7	03385201	4	ROSI LA SCHEM. II	RONDELLI	WASHER



- ① VETRI LATERALI CABINA
- ② VITRES LATERALES CABINE
- ③ LATERAL CABIN GLASSES
- ④ SEITLICHE FENSTERSCHEIBEN FUER KABINE

TAV. 10-05

96100098

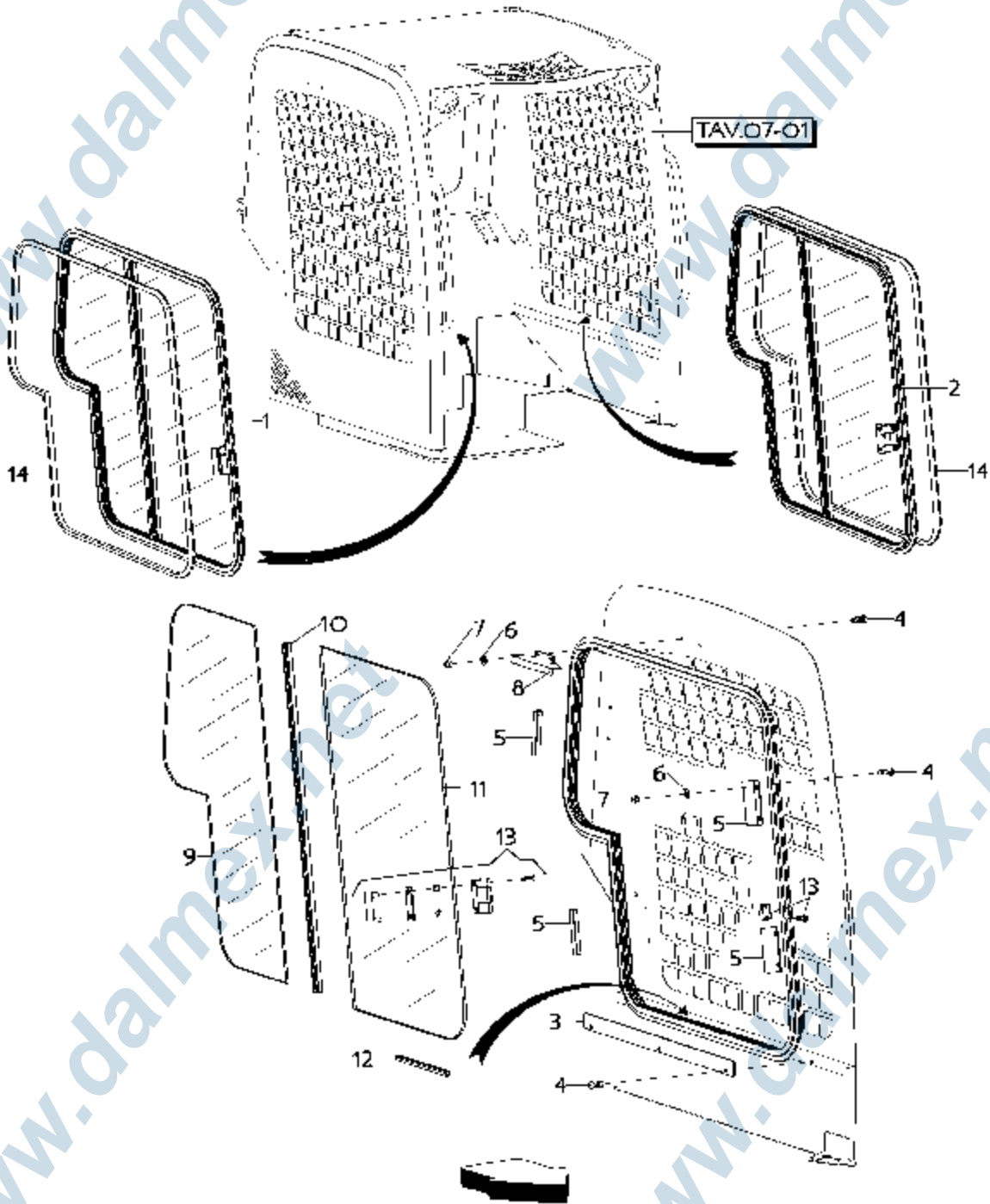



Tav. 10-05 - 96100098

P.	Codice	Q.	① ②	Denominazione Benennung	③	Description	④	Description
1	13640018	1	①	LINEA SERRA SERRAMENTI	③	PER LINEE ACCI	④	SEAL WINDOW
2	13640019	1	①	LINEA SERRA SERRAMENTI	③	PER LINEE ACCI	④	SEAL WINDOW
3	30150453	2	①	SERRA REGOLABILE	③	PER LINEE	④	CLAMP
4	03227702	26	①	VITE SERRAMENTI	③	VITE	④	SCREW
5	30150451	3	①	SERRA REGOLABILE	③	PER LINEE	④	CLAMP
6	03383201	20	①	ROVESCIA SERRAMENTI	③	ROVESCIA	④	WASHER
7	03364010	20	①	FRANGI MUTTER	③	FRANGI	④	NUT
8	30150502	2	①	SERRA REGOLABILE	③	PER LINEE	④	CLAMP
9	62648268	2	①	VITINO SERRAMENTI	③	VITINO	④	CLAMP
10	62648270	2	①	MONTAGNA SERRAMENTI	③	MONTAGNA	④	WASHER
11	62648269	2	①	VITINO SERRAMENTI	③	VITINO	④	CLAMP
12	62648266	2	①	FRANGI SERRAMENTI	③	FRANGI SERRAMENTI	④	CLAMP BLOCK
13	72580135	2	①	MANGIA FRANGI	③	FRANGI	④	CLAMP
14	30320156	2	①	GIUNTA / ORO DISTRIBUTORI	③	GIUNTA	④	CLAMP



- Ⓡ PORTA CABINA
- Ⓡ PORTE CABINE
- Ⓡ CAB DOOR
- Ⓡ KABINENTUER

TAV. 10-06
96100122

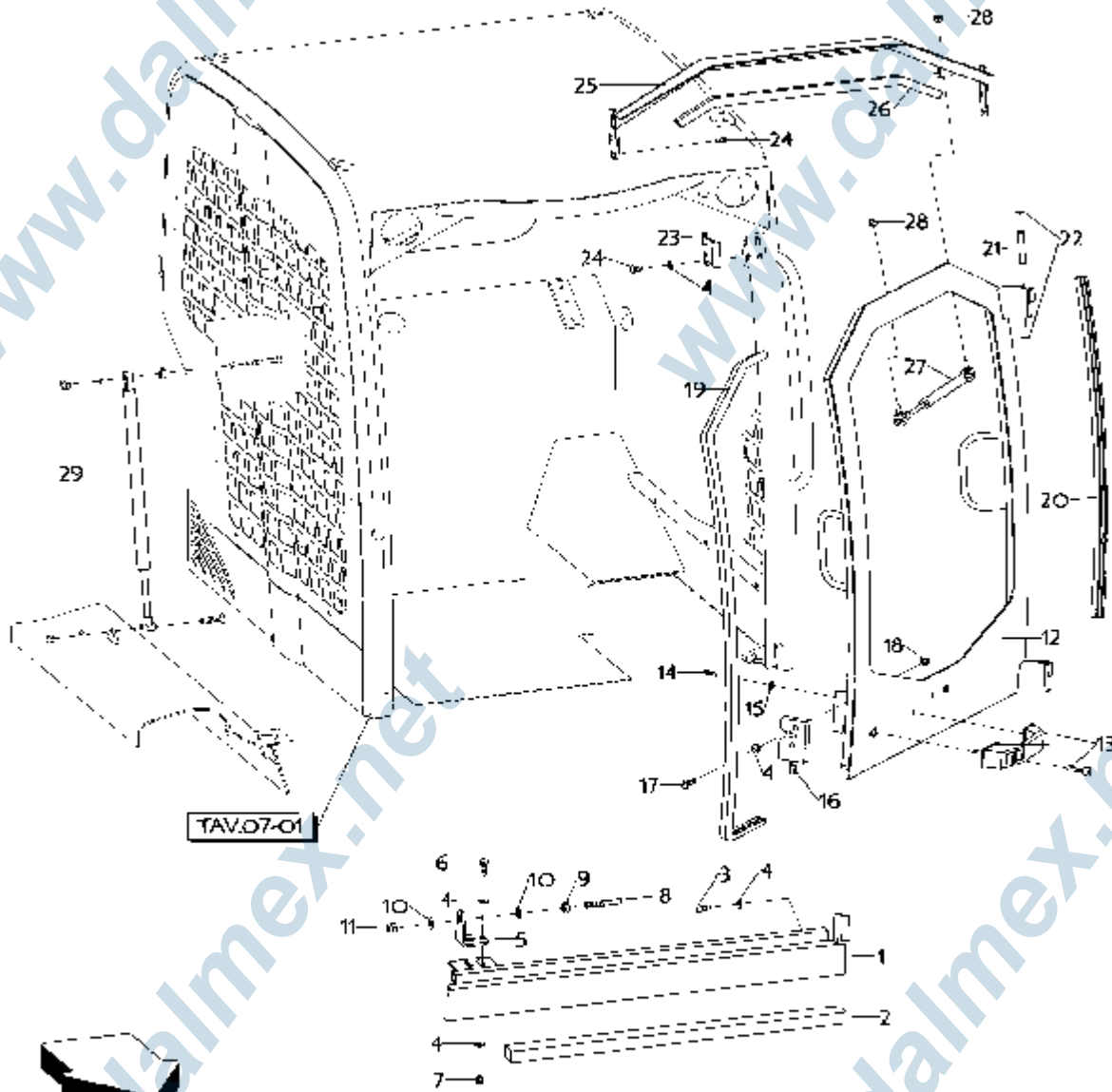



Tav. 10-06 - 96100122

P.	Codice	Q.	Ⓐ Ⓑ	Denominazione Benennung	Ⓔ	Description	ⒼⒷ	Description
1	30150443	1		TRAVILISA KRIEGLSTANGE		TRAVILISA		CROSS 3 AW
2	30320154	1		GEHMEN / ONE DICHTUNG		GEHMEN LIP		GASK 1
3	03234701	4		VII		VIS		SEAL W
4	03385600	12		SCILIAU ROSE TA SCHILIA		RON DILLI		WASER 2
5	95100085	1		SUPPORTO LAL T RUNG		SUPPORT		SH-CP
6	03230601	2		VII		VIS		SEAL W
7	03365100	2		DA 30 MULTI R		CIRCU		NUT
8	95100086	1		FR 3NC FR 3IN		FWD		FIN
9	03366001	1		DA 30 MULTI R		CIRCU		NUT
10	03386201	2		ROSE TA SCHILIA		RON DILLI		WASER 2
11	03366300	1		DA 30 MULTI R		CIRCU		NUT
12	30150424	1		FORZA LIP		FOR		LOCK
13	03572022	1		MANGIA LANTIERE		FOGNET		LAMP
14	03220601	2		VII		VIS		SEAL W
15	03383202	2		SCILIAU ROSE TA SCHILIA		RON DILLI		WASER 2
16	03572023	1		S-ARATURA SCHLOSS		SE-ARTE		LOCK
17	03230801	2		VII		VIS		SEAL W
18	03365400	2		SCILIAU DA 30 MULTI R		CIRCU		NUT
19	30320150	1		GEHMEN / ONE DICHTUNG		GEHMEN LIP		GASK 1
20	30320151	1		GEHMEN / ONE DICHTUNG		GEHMEN LIP		GASK 1
21	95050108	2		FR 3NC FR 3IN		FWD		FIN
22	03420008	4		ANILLO 1 ARA 310 SPRING		ANILLO 1 ARA 310		SPRING
23	95050290	1		GEHMEN / ONE SCHLOSS 2		GEHMEN LIP		LIP
24	03237701	6		VII		VIS		SEAL W
25	30150437	1		TRAVILISA KRIEGLSTANGE		TRAVILISA		CROSS 3 AW
26	30320152	1		GEHMEN / ONE DICHTUNG		GEHMEN LIP		GASK 1
27	03522010	1		ME 3 A GAS GASLIP R		ME 3 SCELTA GAS		GAS SPRING
28	03365001	2		DA 30 MULTI R		CIRCU		NUT
29	23210034	2		ME 3 A GAS GASLIP R		ME 3 SCELTA GAS		GAS SPRING

- ① PORTA CABINA: VETRO
- ② PORTE CABINE: VERRE
- ③ CAB DOOR: GLASS
- ④ KABINENTUER: GLAS

TAV. 10-06A
96100123

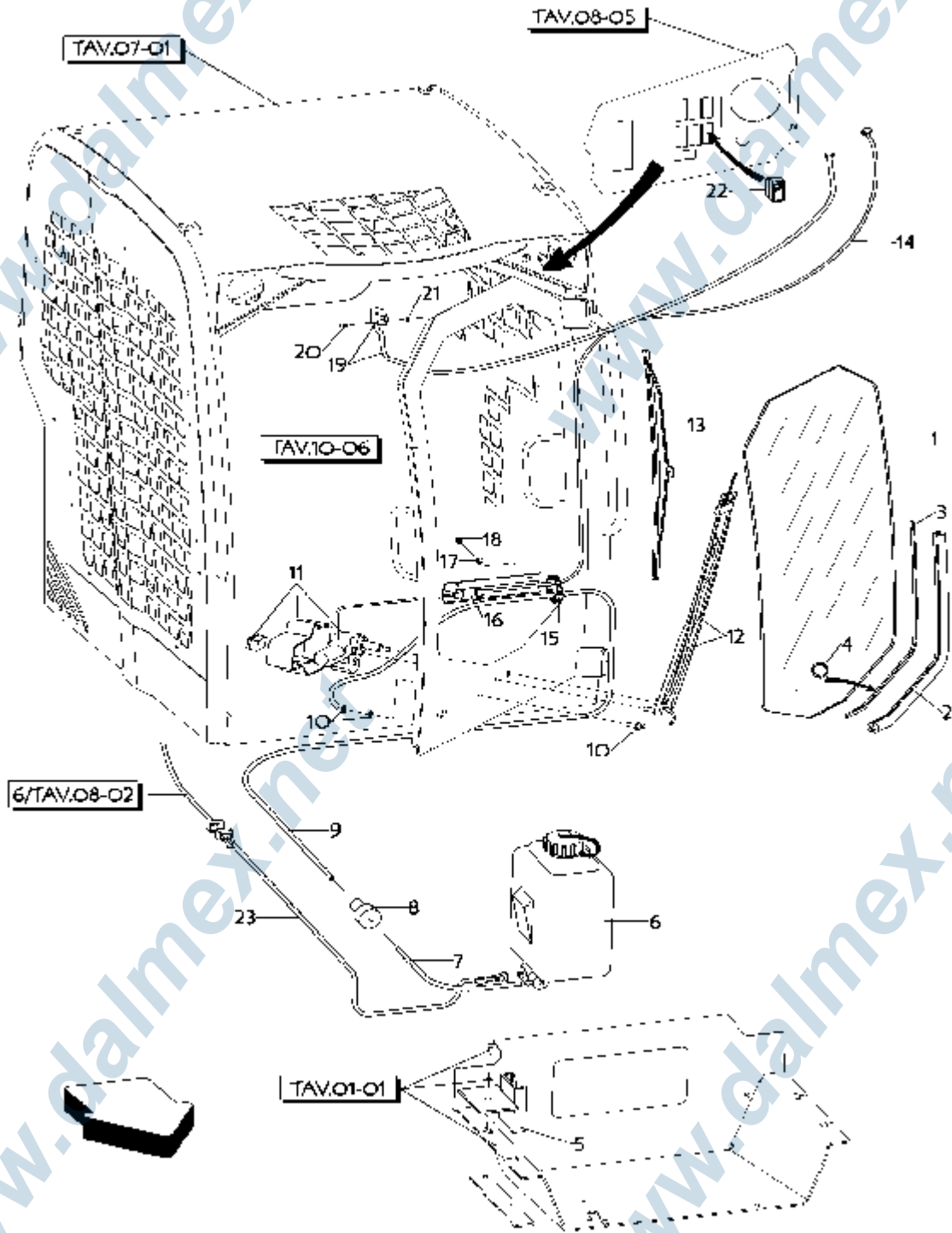



- ① PORTA CABINA: TARGHETTE
- ② PORTE CABINE: PLAQUES
- ③ CAB DOOR: PLATES
- ④ KABINENTUER: SCHILDER

TAV. 10-06B

96100124

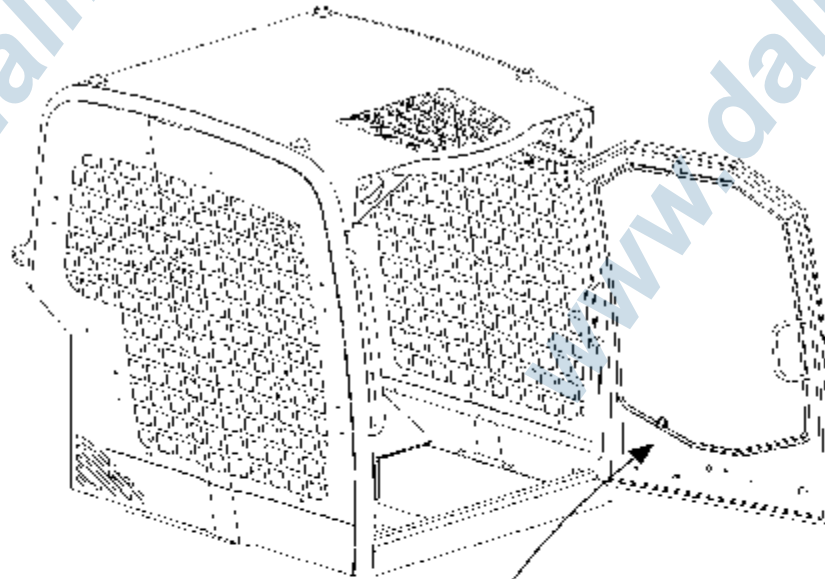



Tav. 10-06B - 96100124

P.	Codice	Q.	① ② Denominazione Benennung	③ Description	④ Description
1	03660191	1	A R S I T T A S C I U T O	R I A C C I U	P A M I

- ① RISCALDAMENTO CABINA
- ② SYSTEME CHAUFFAGE CABINE
- ③ CAB HEATING SYSTEM
- ④ HEIZUNG FUER KABINE

TAV. 10-07
96100128

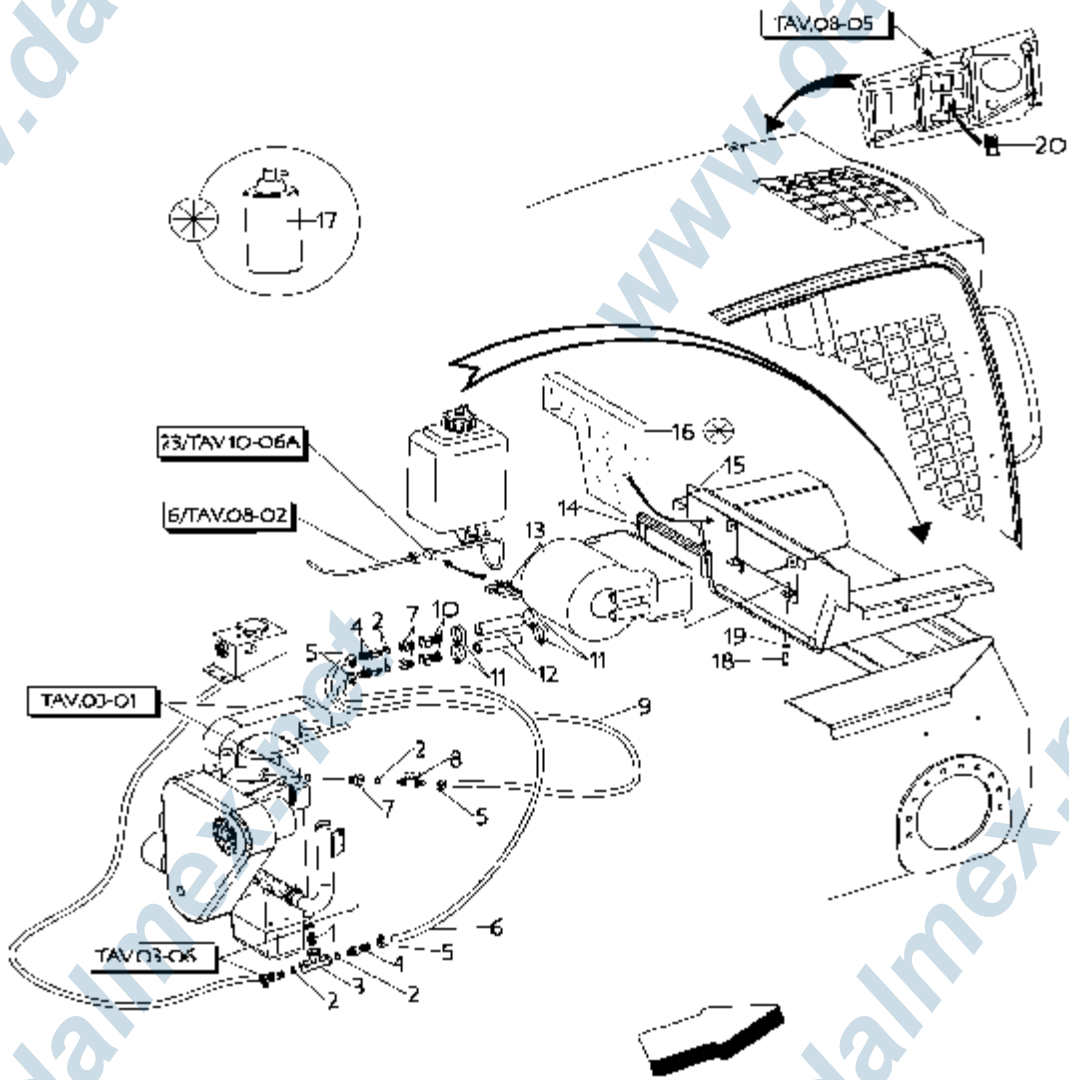



Tav. 10-07 - 96100128

P.	Codice	Q.	Ⓐ Ⓑ	Denominazione Benennung	Ⓕ	Description	Ⓖ	Description
1	13152700	1		RACCORDO ANSIC FUSO		RACCORDO		CONN. CION
2	03168500	5		GIUNTI / ONI DICI / ONG		GIUNTI / ONI		GRAB. I
3	03631505	1		GIUNTI / ONI V. TRIN. DUNG		ANS. MIB. AG		LUNG. CION
4	33143505	3		RACCORDO ANSIC FUSO		RACCORDO		CONN. CION
5	13572700	4		FASCIA SCHELE		MANO		C. AVP
6	27200343	1		URO RODRI		JYAL		P-PI
7	13154400	3		RACCORDO ANSIC FUSO		RACCORDO		CONN. CION
8	03193810	1		GIUNTI / ONI FAIR		RODRI		LAF
9	27200342	1		URO RODRI		JYAL		P-PI
10	33140302	2		RACCORDO ANSIC FUSO		RACCORDO		CONN. CION
11	13577400	4		FASCIA SCHELE		MANO		C. AVP
12	27200344	2		URO RODRI		JYAL		P-PI
13	27160010	1		A. SCHELE LUBRIFICAZIONE		A. SCHELE		UNI. L. MIB.
14	30320003	1		GIUNTI / ONI DICI / ONG		GIUNTI / ONI		GRAB. I
15	30060427	1		GIUNTI / ONI KASIK		GIUNTI / ONI		GRAB. CION
16	30320275	1		PANNI / C BIBBIER / CION		PANNI / C		PAN
17	03709010	1		SCHELE (QUANTITA S. CION. DO. SIG. KVA) KILLO / (MIB) JL. NAC. L. MIB. R.		A. SCHELE (QUANTITA S. CION. DO. SIG. NO.)		A. SCHELE (QUANTITA ACCORDAZIONE CON. CION. DO. SIG. NO.)
18	03217503	4		VI SCHELE		VI		SCHELE
19	03383311	4		RODRI SCHELE		RODRI		MANO / C
20	13472904	1		PIRELLI / CION. BISCAL. CION. DO. SIG. NO.) LUBRIFICAZIONE		PIRELLI / CION. BISCAL. CION. DO. SIG. NO.)		LUBRIFICAZIONE



- ① PROTEZIONE « TOP GUARD »
- ② TOIT PROTECTION "TOP GUARD"
- ③ OVERHEAD "TOP GUARD" PROTECTION
- ④ SCHUTZDACH "TOP GUARD"

TAV. 10-08

96100099

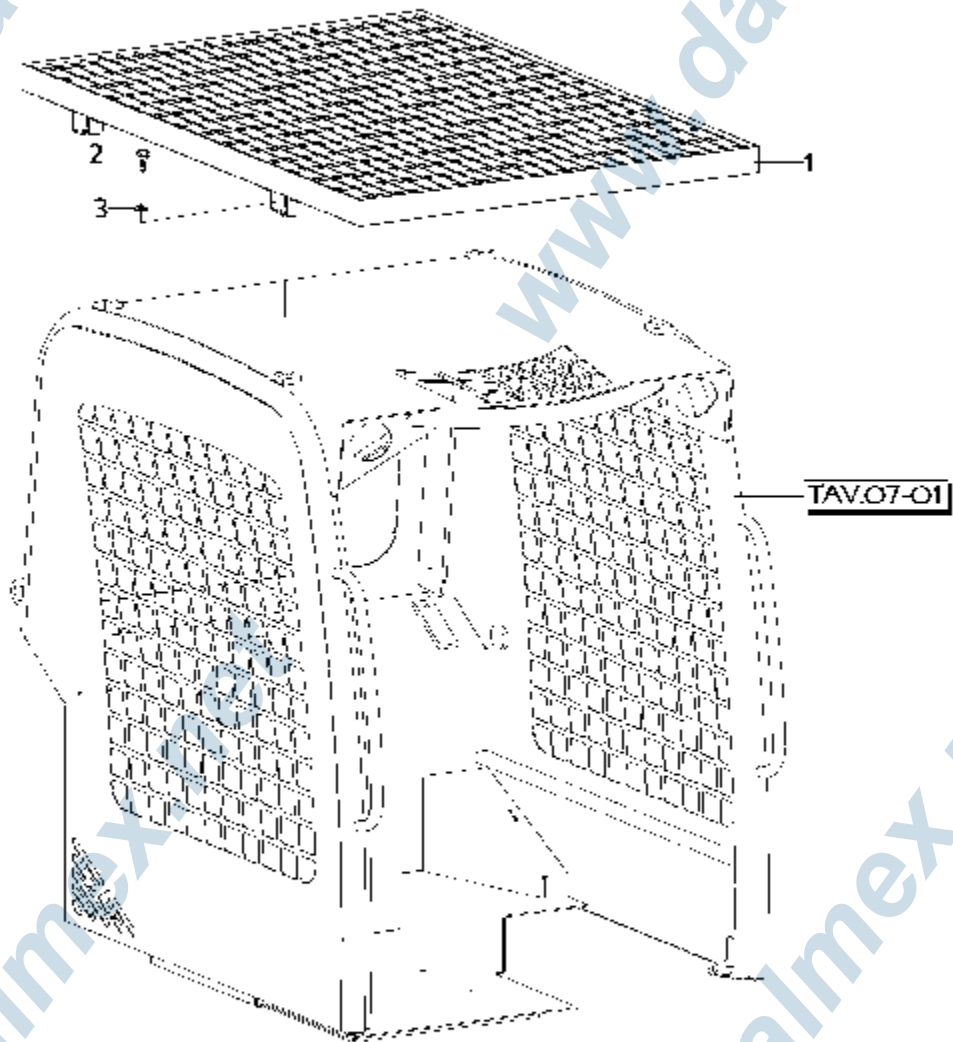



Tav. 10-08 - 96100099

P.	Codice	Q.	① ② Denominazione Benennung	③ Description	④ Description
1	30150459	1	FRONTI ZICNI SCHULTZ	FRONTI ZICNI	FRONTI ZICNI
2	03270300	4	VII SCHRAUBEN	VII	SCHRAUBEN
3	03389300	4	ROSETTA SCHULTZ	ROSETTE	ROSETTE